



Intructions manual

Motor
regulation

Sm-Klebeteknik Vertriebs GmbH
Otto-Hahn-Str. 19a, 52525 Heinsberg
Tel.: +49 2452 / 9172-0; Fax.: +49 2452 / 9172-20
www.sm-klebeteknik.de

Page 1 of 6

Electronic controller W 2000 for electronic commutated D.C – motors

1. General informations

The electronic controller W 2000 was getting developed for the use of electronic commutated DC-Motors. It is a compact component for one phasic main supply.

All important power- and regulation signals for the use of these motors are getting evaluated by the electronic controller.

An adaptation of the regulation parameters to the motor is not necessary.

Only an adjustment of the nominal speed of the motor to the regulation electric must be processed.

2. Technical Data W 2000

Mains supply:	230 V +/- 10%, 50 ... 60 Hz
Fan - out current:	2,5 A (Effective amount)
Peak current:	3,5 A (Effektiv amount) for 5 seconds, after this the electronic is getting switched off.
Motor discharge power:	max. 500 W (Operational mode S1)
Fuse:	6,3 A f
Regulation range:	untill 1:30 without additional tachometer
Regulation tolerance:	< 1 % (according to nominal speed)
Working temperature:	40 °F – 100 °F (5 °C – 40 °C)
Storing temperature:	- 10 °F – 160 °F (- 10 °C – 70 °C)
Dimensions:	(L) 160 mm x (W) 147 mm x (H) max. 90 mm



Intructions manual

Sm-Klebeteknik Vertriebs GmbH
 Otto-Hahn-Str. 19a, 52525 Heinsberg
 Tel.: +49 2452 / 9172-0; Fax.: +49 2452 / 9172-20
www.sm-klebeteknik.de

Motor regulation

Page 2 of 6

3. Sketch Electronic board W 2000

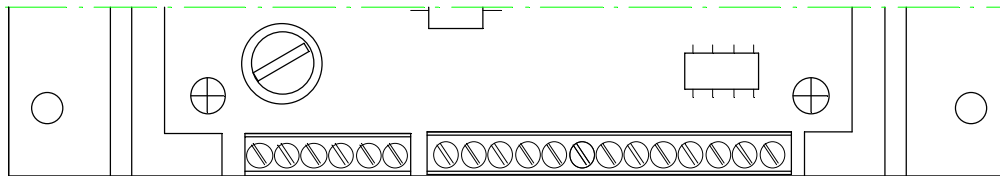
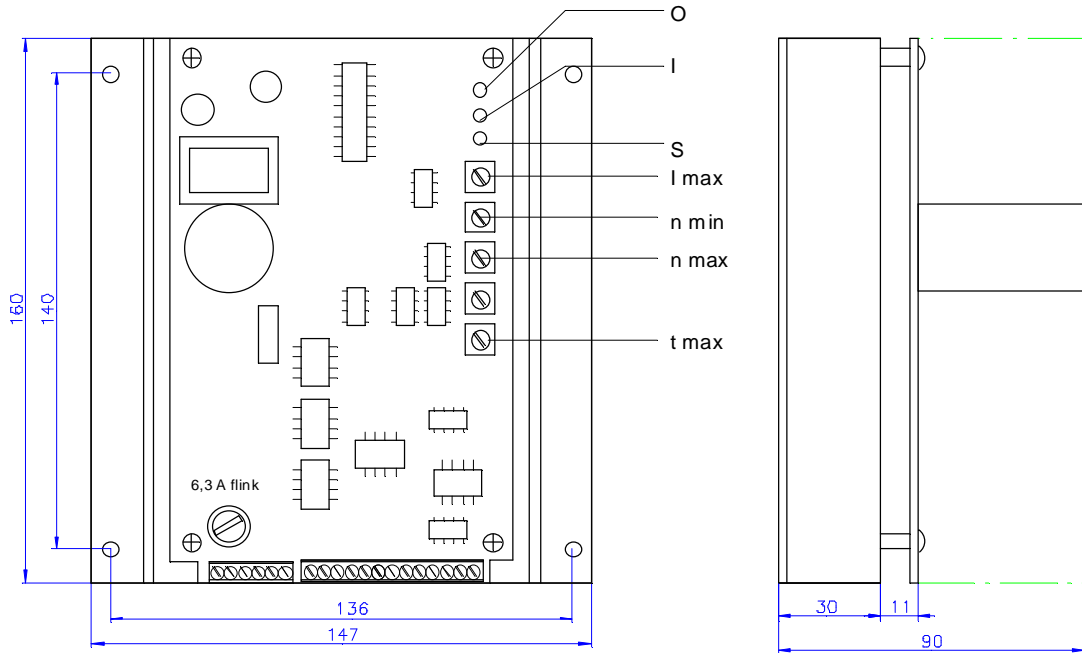

1 2 3 4 5 6 7 8 9 10 11 12 13 14 15 16 17 18 19

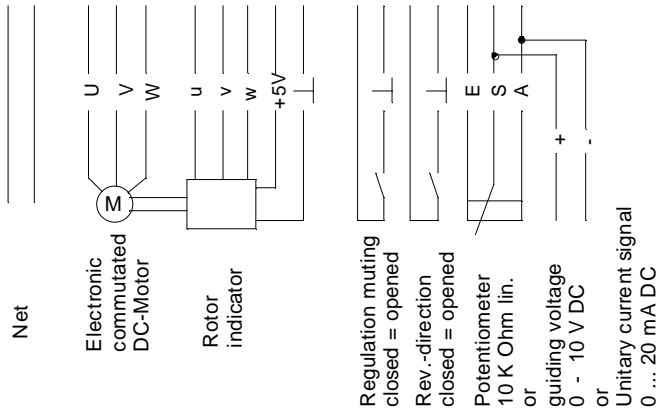



Intructions manual

Sm-Klebetchnik Vertriebs GmbH
Otto-Hahn-Str. 19a, 52525 Heinsberg
Tel.: +49 2452 / 9172-0; Fax.: +49 2452 / 9172-20
www.sm-klebetchnik.de

**Motor
regulation**

Page 3 of 6

4. Connecting terminals

<u>Connecting terminal</u>	<u>Name</u>
1	Net L
2	Net N
3	
4	Motor connection U
5	Motor connection V
6	Motor connection W
7	Rotor indicator u
8	Rotor indicator v
9	Rotor indicator w
10	Distribution voltage +5V DC for Rotor indicator
11	Mass Rotor indicator

5. Steering entrance

All steering entrances are galvanic divided from the net.

<u>Connecting terminal</u>	<u>Name</u>
12	Not in use
13	Regulation muting
14	Regulation muting of the mass
15	Direction of rotation change over
16	Direction of rotation change over for mass
17	Allowed set point E
18	Allowed set point S (guiding voltage +)
19	Allowed set point A (guiding voltage -)

Regulation muting: High level stage in use, when terminal 13 connected to mass (terminal 13 to 14).

Actuation runs free when terminal 13 is opened.

Direction of rotation change over: Rotation right: terminal 15 open
Rotation left: terminal 15 on masses (terminal 15 to 16)



Intructions manual

Motor
regulation

Sm-Klebeteknik Vertriebs GmbH
Otto-Hahn-Str. 19a, 52525 Heinsberg
Tel.: +49 2452 / 9172-0; Fax.: +49 2452 / 9172-20
www.sm-klebeteknik.de

Page 4 of 6

Allowed set point: - Potentiometer 10 kWlin. / 0,3 W
(pre-choice over jumper I / U, Pos. U)

terminal 17,18 and 19

- guiding voltage 010 V DC (pre-choice
over jumper I / U, Pos. U)

(Internal resistance of source $R_E \approx 100 \text{ kW}$)

terminal 18: +

terminal 19: mass

- Current signal 0 20 mA,
End resistance $R_E = 500 \text{ W}$
(pre-choice over jumper I / U, Pos. I)

terminal 18: +

terminal 19: mass

6. Adjustment potentiometer

I_{\max} : Adjustment current muting.

The maximum motor current is adjustable at the potentiometer.

When I_{\max} is reached the yellow LED shines.

I_{\max} must be adjusted in this way, that the yellow LED is not shining permanently.

T_{\max} : Adjustment run-up ramp.

Jumper t1 / t2 in position t1: run-up ramp activated.

When the drive is getting started over the regulation muting the revolution setting value is getting decelerated by the pre-adjusted run-up time. (slowly rewinding)

When the regulation muting is open the actuation is going to drift.

n_{\max} : Alignment motor nominal speed by maximum revolution setting value (n_N see rating plate of the motor).

n_{\min} : Alignment minimum motor speed by minimum revolution setting value.

Offset: Adjustment was made in-plant and sealed. Changing of the adjustment can cause damage at the electric or the motor.



Intructions manual

Motor
regulation

Sm-Klebetchnik Vertriebs GmbH
Otto-Hahn-Str. 19a, 52525 Heinsberg
Tel.: +49 2452 / 9172-0; Fax.: +49 2452 / 9172-20
www.sm-klebetchnik.de

Page 5 of 6

7. Terminals

I / U: Revolution setting value Current / Voltage
t1 / t2: Adjustment run-up ramp (always set position t1)

8. Display

LED green: - line voltage.
„ O „ - Fuses of the electric are OK.

LED yellow: - ready for word (regulation muting activated, terminal rails
„ I „ 13/14 open)
- Current level I_{max} obtained.
- Should not shine permanently during work.

LED red: - Fault.
„ S „ - Peak current obtained.
- If current awaits for approx. 5 sec., the electric is getting switched off.

9. General informations for installation

Allow only qualified personnel to perform installation. The respective rules for the prevention of axxicents as well as any other commonly recognized safety regulations and industrial medical regulations are to be observed.

Protection: By switch-on of the electric highly current at make appears because of the charge action in the intermediate circuit.

Take care for an adequate protection at the electric mains.

Fault current: Conventional FI-protective switches are not only suitable, because of the appearance of leakage current by electromagnetic compatibility-caused interference supressors.

Protective conductor connection: It is not allowed to run the electric without efficient ground connections which accords to the public laws.



Intructions manual

Motor
regulation

Sm-Klebeteknik Vertriebs GmbH
Otto-Hahn-Str. 19a, 52525 Heinsberg
Tel.: +49 2452 / 9172-0; Fax.: +49 2452 / 9172-20
www.sm-klebeteknik.de

Page 6 of 6

10. Special informations for installation

Use only shielded lines between motor and electric. For the motor connection use only a four-wired shielded cable with a minimum diameter of 1 mm^2 / wire.

Use only a five-wired shielded cable for the trip line to the motor with a minimum diameter of $0,5 \text{ mm}^2$ / wire.

The lines must layed under the bottom side of the unit and connected at the clamps.

11. Initiation

Before switching on the electric the must be adjusted to the minimum speed, the current limiter I_{\max} must be adjusted to minimum current.

The regulation muting must be activated, binding post 13/14 open.

After this the net can be switched on.

If the net is getting switched on by bridged binders 13/14, the actuation is not running and the electric signals a fault (red LED activated).

Considering all safety instructions the drive can be started to operate by using the regulator blocking (binders 13/14).

Adjust the potentiometers n_{\min} and n_{\max} to the needed speed (by applied revolting setting value).

Now the motor runs according to the given parameters.

Now the current limiter I_{\max} and the ramp-up time has to be adjusted.

In case the electronic shows an „ Error „, the regulator muting has to be opened for at least 10 seconds before restarting the drive again.

12. Possible errors

- | | |
|--|--|
| 1. No function, green LED is not shining. | Check fuses and power supply. |
| 2. Motor does not turn, yellow LED shines. | Check the connections. |
| 3. Motor does turn, red LED shines. | Motor is probably connected correctly, check the wiring. |
| 4. Motor does not turn, red and yellow LED shines. | Drive is blocked and overloaded. |