



**ELOTECH**

INDUSTRIELELEKTRONIK GMBH



Format: 194 x 98  
Installation depth: 122 mm

mm

## **8, 10, 12, 16- Zones Two - point ( heat-only) Temperature Controller with LCD-Display**

### **R2500**

Option: Heater current monitoring  
Option: CANopen interface  
Option: Profibus DP interface  
Option: Modbus interface  
Option: Ser. Interface RS232, RS485

### **DESCRIPTION AND OPERATING MANUAL**

# 1. Contents

1.	Contents .....	2
2.	Type Code .....	2
3.	Connection Diagram: R2500 - 821, A21, C21, E21 .....	3
4.	Connection Diagram: R2500 - 826, A26, C26, E26 .....	4
5.	Display and Keyboard, general .....	5
5.1	Menu 1 .....	6
5.2	Menu 2 .....	8
6.	Parameter Lists .....	12
6.1	Menu 2, Controller Parameters; zone dependent (F1) .....	12
6.2	Menu 2, Device Parameters (F2) .....	18
7.	Interface .....	23
7.1	CANopen, general .....	23
7.2	Ser. Interface, general .....	23
7.3	Profibus-DP, general .....	24
8.	Technical Data .....	25
9.	Error displays .....	26
10.	Installation Instructions .....	26

**Please read this operating manual carefully before starting up. Observe the installation and connecting instructions. Take care to the separat interface- and data transmission descriptions.**

**See: [www.elotech.de](http://www.elotech.de)**

## Disclaimer of liability

We have checked the contents of the document for conformity with the hardware and software described. Nevertheless, we are unable to preclude the possibility of deviations so that we are unable to assume warranty for full compliance. The information given in the publication is, however, reviewed regularly. Necessary amendments are incorporated in the following editions. We would be pleased to receive any improvement proposals which you may have.

## 2. Type Code

R 2500 - aaa - x - y - 000 - d - z		
↓	↓	↓
	0: standard 5: with heater current monitoring (only with bist. voltage outputs)	1: power supply: 230 V AC 2: power supply: 115 V AC 3: power supply: 24 V AC 5: power supply: 24 V DC
↓	0: sensor programmable: RTD (Pt100-DIN), 2- or 3-wire; Type L (Fe-CuNi), Type J; Type K (NiCr-Ni)	0: without serial interface 2: ser. interface RS232-C Protocol: ELOTECH – standard, Modbus 4: ser. interface RS485 Protocol: ELOTECH – standard, Modbus InterBus-S via gateway M-IBS -5 5: ser. interface 0/20mA Protocol: ELOTECH - standard 7: CAN, CANopen Device Profile DS-404 8: Profibus DP, acc. EN 50170
↓		
821	8 - zones heat-only-cooling controller;	control outputs: all, relais (not with heater current monitoring)
826	8 - zones heat-only-cooling controller;	control outputs: : bist. voltage signal. Com.: -
831	8 - zones heating-off-cooling controller;	control outputs: heating and cooling: relay
836	8 - zones heating-off-cooling controller;	control outputs: heating and cooling, bist. voltage signal
837	8 - zones heating-off-cooling controller;	control outputs: : „heating“: bist. voltage signal. Com.: - „cooling“: relay
A21	10 - zones heat-only-cooling controller;	control outputs: all, relais (not with heater current monitoring)
A26	10 - zones heat-only-cooling controller;	control outputs: : bist. voltage signal. Com.: -
C21	12 - zones heat-only-cooling controller;	control outputs: all, relais (not with heater current monitoring)
C26	12 - zones heat-only-cooling controller;	control outputs: : bist. voltage signal. Com.: -
E21	16 - zones heat-only-cooling controller;	control outputs: all, relais (not with heater current monitoring)
E26	16 - zones heat-only-cooling controller;	control outputs: : bist. voltage signal. Com.: -

### 3. Connection Diagram: R2500 - 821, A21, C21, E21

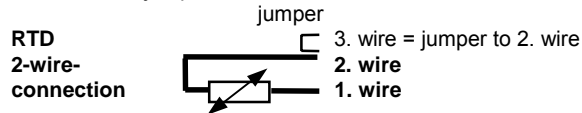
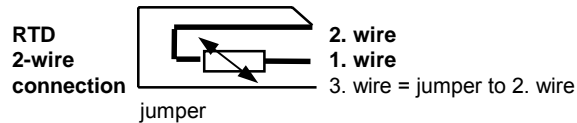
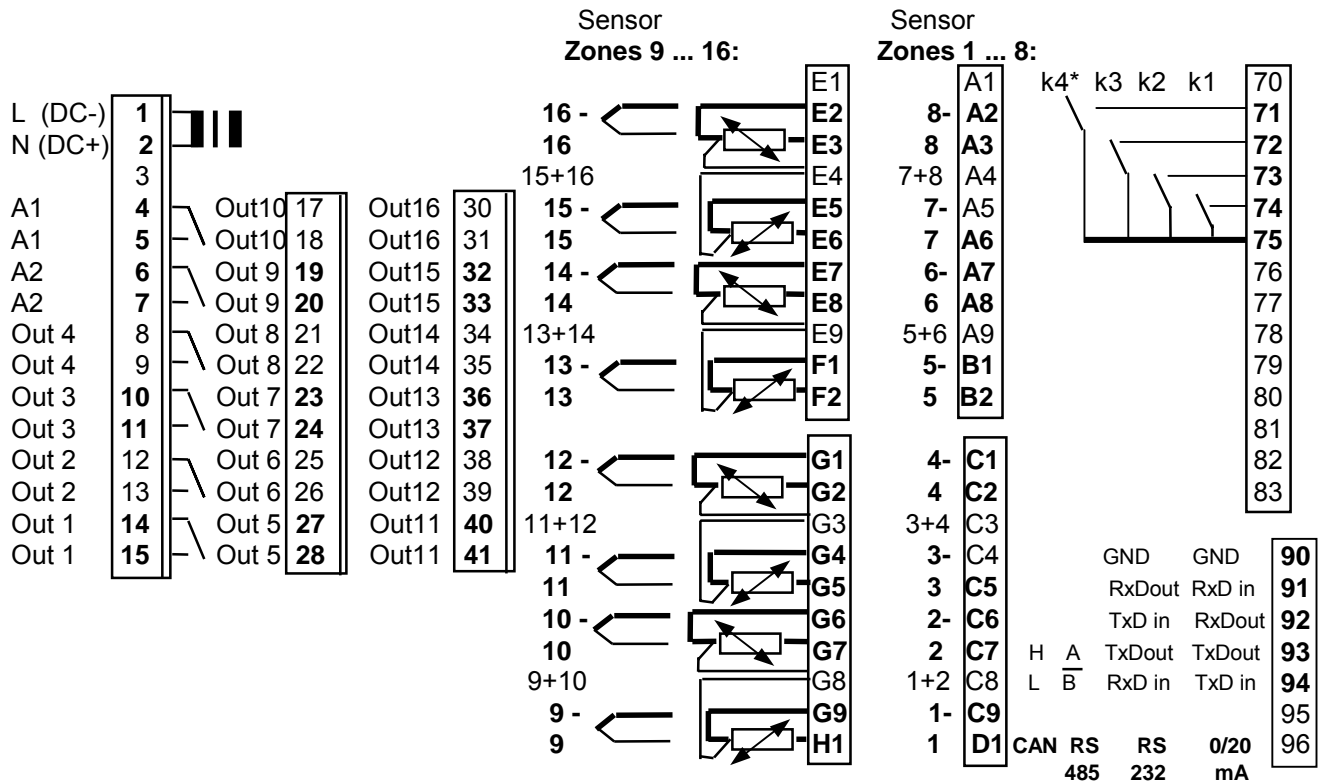

**Control output OUT 1:** Zone 1; control output „heating“ or „cooling“, relay to

**Control output OUT 16:** Zone 16; control output „heating“ or „cooling“, relay

**Alarm Output A1:** Alarm 1 ( Temperature- or heater current monitoring alarm A1 for all zones)

**Alarm Output A2:** Alarm 2 ( Temperature- or heater current monitoring alarm A2 for all zones)

**Setpoint Controlling:** K1: open = Setpoint 1 (SP1) valid  
 K1: closed = Setpoint 2 (SP2) valid, for all zones

**Adjustment lock (LOC):** K2: open = Adjustment lock only via „software code“ (see parameter: LOC)  
 K2: closed. = Adjustment locked according to the choosen „software code“.

**Setpoint changing:** K3: open = individual setpoint adjustment for each zone  
 K3: closed = if setpoint has been changed in one zone, this new setpoint is valid (will be overtaken) for all other zones automatically.

**CAN-Interface:** K4: open = CAN: „operational“. Operation only with CANopen proctoll.  
 K4: closed = CAN: „operational“ always active.  
 „k4“ must be closed, if the instrument is equipped with a CAN-interface but not used.

## 4. Connection Diagram: R2500 - 826, A26, C26, E26

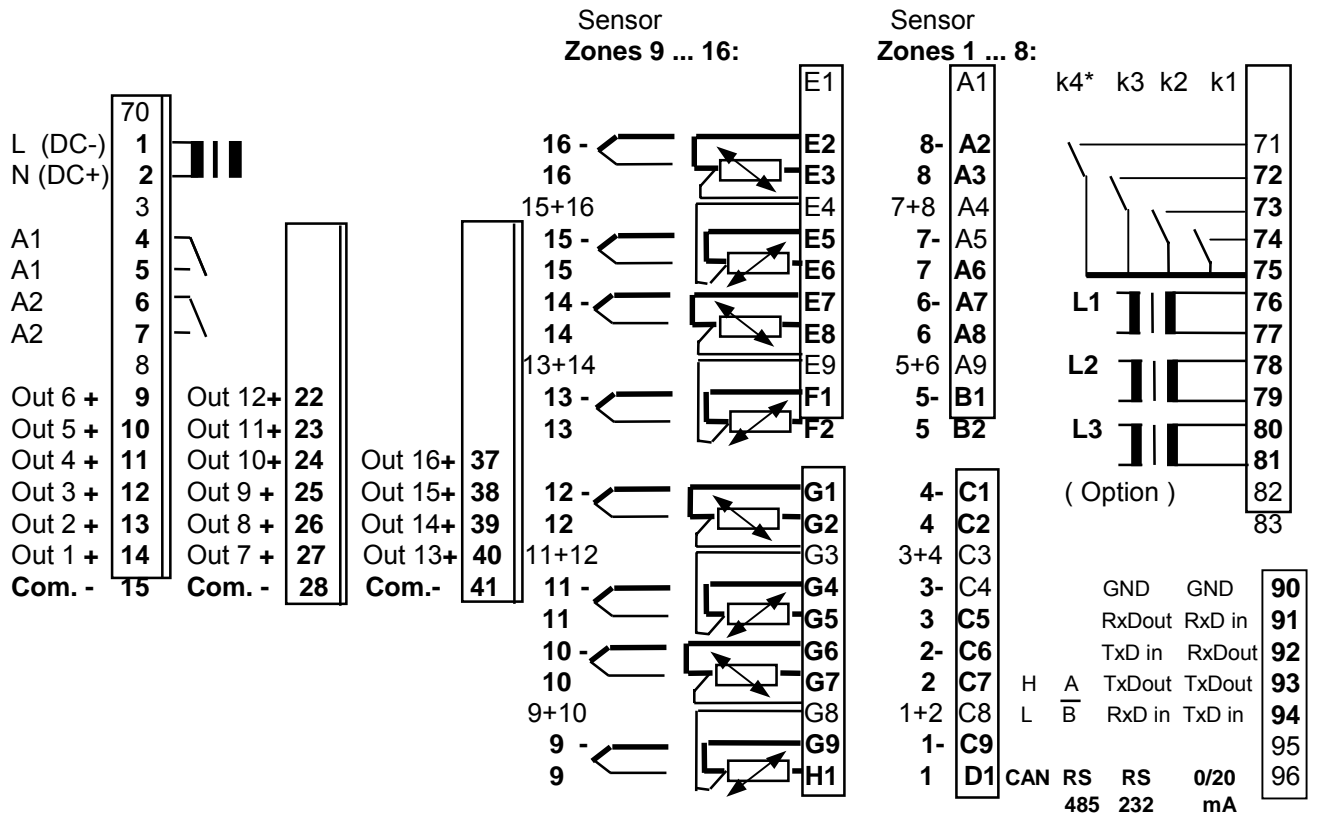

It is not permitted to connect the grounds of the sensor-inputs and bist. voltage-outputs with each other.

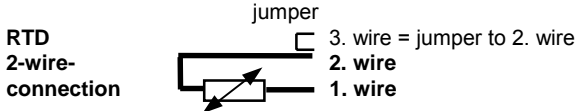
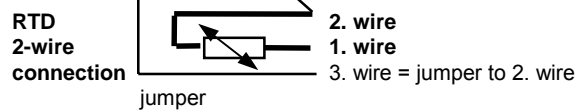

**Control output OUT 1:** Zone 1; control output „heating“ or „cooling“, relay to

**Control output OUT 16:** Zone 16; control output „heating“ or „cooling“, relay

**Alarm Output A1:** Alarm 1 ( Temperature- or heater current monitoring alarm A1 for all zones)

**Alarm Output A2:** Alarm 2 ( Temperature- or heater current monitoring alarm A2 for all zones)

**Setpoint Controlling:** K1: open = Setpoint 1 (SP1) valid  
K1: closed = Setpoint 2 (SP2) valid, for all zones

**Adjustment lock (LOC):** K2: open = Adjustment lock only via „software code“ (see parameter: LOC)  
K2: closed. = Adjustment locked according to the choosen „software code“.

**Setpoint changing:** K3: open = individual setpoint adjustment for each zone  
K3: closed = if setpoint has been changed in one zone, this new setpoint is valid (will be overtaken) for all other zones automatically.

**CAN-Interface:** K4: open = CAN: „operational“. Operation only with CANopen protocoll.  
K4: closed = CAN: „operational“ always active.  
„k4“ must be closed, if the instrument is equipped with a CAN-interface but not used.

**Heater current monitoring:** 1 current – transformer / phase  
Single phase operation: terminals 76,77: L1  
Three-phase operation: terminals 76 – 81: L1, L2, L3

## 5. Display and Keyboard, general

The device is equipped with a LCD display.

After switching on and initialising the device, the actual values of all connected control zones are displayed.

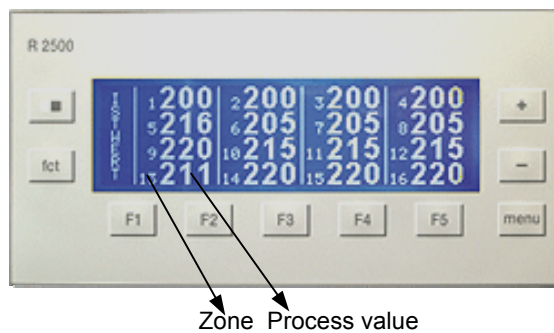

Er.H display: Measurement range exceeded or sensor fault  
 Er.L display: Measurement range undershot or sensor short circuit  
 No display: Respective control zone switched off

The operation of the device is menu-driven.

Most of the individual parameters are displayed in plain text.

The used language can be selected.

See: Menu 2 -> F2: Device Parameter / Geräteparameter -> Parameter "Language / Sprache"

### Key functions:



Select menu function  
 Return from another display to the menu  
 Two menus are available



-



Soft keys.  
 Function varies according to superimposed descriptor.



Value adjustment (e.g. setpoint or control parameter)



Value adjustment (e.g. setpoint or control parameter)



Key with special function



Contrast setting upon additional actuation of + or - keys

## 5.1 Menu 1

menu key:

### Display of Menu 1



F1: Process Values  
F2: Setpoints  
F3: Tendency Display  
F4: Process Overview

F1 key:

### Large display of actual values of all control zones connected

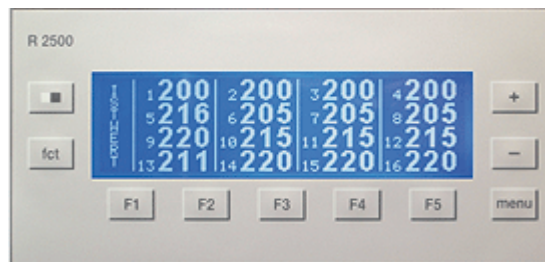

Er.H display: Measurement range exceeded or sensor fault  
Er.L display: Measurement range undershot or sensor short circuit  
No display: Respective control zone switched off

Use the **F2**, **F3** or **F4** keys to select a different display or use **menu** key to return to Menu 1.

F2 key:

### Display of all actual values and their respective setpoints

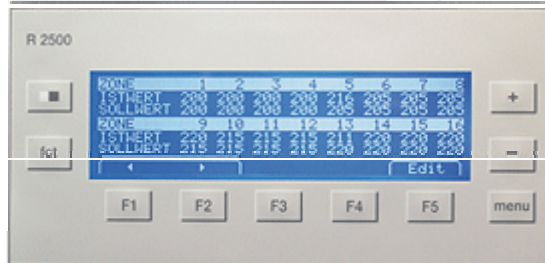

The setpoint displayed may be:

1. Setpoint SP 1 (normal case)
2. Setpoint SP 2 (if k1 closed)
3. Manual output ratio, display: H ...

**F5 key (Edit): Setting (edit): Setpoint 1 or manual output ratio**

First select the zone to be altered using the **F1** (◀) and **F2** (▶) keys. This zone and the current setpoint or the manual output ratio are displayed above the F3 and F4 keys.

**ZONE 5: 216**

If setpoint 2 is active, then "SP2" is displayed instead of the setpoint. SP2 can only be adjusted in the "F1: Controller Parameters" menu.

Adjust the new setpoint using the + / - keys.  
• Enter: The setpoint set is not the same as the current setpoint.

Once the new setpoint has been set, use the **F5** key (Enter) to confirm or select the setpoint of the next zone using the **F1** / **F2** keys.

Use the **F1**, **F3** or **F4** keys to select a different display or use **menu** key to return to Menu 1.

**F3 key:**

**Temperature Tendency- and Alarm display**

This function shows the temperature trend and alarm status of outputs A1 and A2. The display allows rapid overview of the temperature conditions of the control zones connected.



— : Deviation of actual value from setpoint: ≤ 1% of measurement range

█ : Positive or negative deviation: ≥ 3% of measurement range

AL1 line: when Alarm A1 is active, " \* " is displayed under the respective zone

AL2 line: when Alarm A2 is active, " \* " is displayed under the respective zone

If the option "Heater current monitoring" is active and if a continuous current flow has been determined (failure of the semiconductor switches) then the following message is reported: "Current failure alarm".

Use the **F1**, **F2** or **F4** keys to select a different display or use **menu** key to return to Menu 1.

**F4 key:**

**Process overview**

Display of 4 zones at a time with:

zone number, actual value, current setpoint, reference ratio display, alarm display, heater current display and information (status) messages.

Zone	Temp.	Set	Y%	Al.	Amp.	Info
1	200	200	34	1	15.8	Opt
2	202	200	32		17.1	
3	210	210	37	2	20.0	Ramp
4	220	220	38		25.3	

re: actual value: OFF: Zone switched off  
 Er.H: Measurement range exceeded or sensor fault  
 Er.L: Measurement range undershot or sensor short circuit

re: setpoint: MAN: Zone operates with manual output ratio (display under "Y")  
 Index 2: Setpoint 2 active (e.g.: 210<sub>2</sub>)

re: Y%: The current reference output ratio is displayed in the reference ratio display. It cannot be changed. It is displayed as a percentage of the installed output. \* after the percentage: control output "on"

re: Al.: Display: 1 Alarm 1 active (temperature or heater current alarm)  
 Display: 2 Alarm 2 active (temperature or heater current alarm)  
 Display: A Heater zone failure, continuous current flow

re: Info: Opt Self-optimisation active  
 Ramp Setpoint ramp active  
 E.xx Fault messages, see below

The next four zones are called up with the **F4** (▲) key.  
 The previous four zones are called up with the **F5** (▼) key.

Use the **F1**, **F2** or **F4** keys to select a different display or use **menu** key to return to Menu 1.

**F5 key:**

Switch to Menu 2

## 5.2 Menu 2

**menu key:** Entry to Menu 1.

**F5 key:** Select Menu 2.

MENU 2	
F1 :	Controller Parameters (zone dependent)
F2 :	Device Parameters
F3 :	Recorder Function
F4 :	Device Status

MENU 1

**F1 key:** Control parameters. Adjustment required for each control zone.

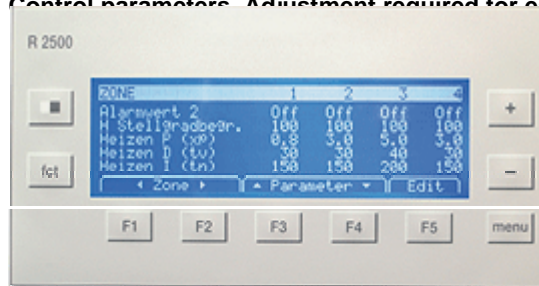

Display of the first 5 available parameters for 4 zones at a time.

Zone	1	2	3	4
Setpoint 1				
Setpoint 2				
Rising ramp				
Falling ramp				

**F3 key:** Scroll up parameter list

**F4 key:** Scroll parameter list downwards

Alarm value A1  
 Alarm value A2  
 Max output ratio  
 P (P-band)  
 D (rate time)  
 I (reset time)  
 Cycle time  
 Switch sensitivity (only if P=Off)  
 Autotune  
 Process offset  
 Zone on/off  
 Controller configuration  
 Sensor selection  
 Setpoint limit max.  
 Setpoint limit min.  
 Softstart function (Sst)  
     if activated (on): Sst output ratio  
                           Sst setpoint  
                           Sst duration time  
 Output mode (Controller or actuator operation)  
 Copy to zone

For a more detailed list of parameters with their setting ranges see below.

**F5 key (Edit): Setting (editing) the parameters**

Zone	1	2	3	4
Setpoint 1	234			
Setpoint 2				
Ramp rising				
Ramp falling				

The parameter to be edited / changed (here: setpoint) is set on a white background and can now be changed using the + / - keys.

If a new parameter is selected, then the set value is automatically adopted.

Parameters within one zone can be selected using the **F3** and **F4** keys.

A different zone can be selected using the **F1** and **F2** keys.

**F5** key (Enter): End parameter default (edit).

**menu** key: Return to Menu 2

**F2** key:

**Device parameters. Settings apply to the device and to all control zones.**

For a list of parameters with the respective setting ranges and more detailed explanation see below.

Display of first 5 parameters available.

Device Parameters
Pt100(RTD) / TC (thermo couple)
Alarm configuration A1
Switching behaviour A1
Alarm configuration A2
Switching behaviour A2

**F3** key: Scroll up parameter list

**F4** key: Scroll parameter list downwards

Only if equipped with "heater current monitoring" \*):

Current detection cycle

Delay time, relay A1 ( or A2)

Min. leakage current

Adjustment lock

Zones offset

Remote

Device address

Data format

Baud rate

Sample time (See: recorder function)

Language

\*) The number of parameters displayed varies according to the version and configuration of the device.

**F5 key (Edit): Setting (editing) the parameters**

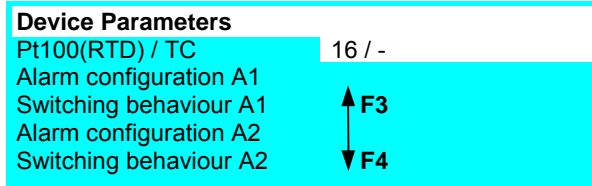

The parameter to be edited is set on a white background and can now be changed using the + / - keys.

If a new parameter is selected, then the previously set value is automatically adopted.

The parameters can be selected using the **F3** and **F4** keys.

**F5 key (Enter):** Parameter default (edit) terminated.  
**menu key:** Return to Menu 2

**F3 key: Recorder function.**

Display of actual value path over time. The time axis is defined by the "Sample time" parameter.

This function enables the user to observe the transient response and the timing behaviour of the controller for the respective control zone without the need for any additional devices and to parameterise these accordingly.

In the event of a fault the course taken by the actual value within a given period of time can be retrospectively examined prior to the occurrence of the fault.

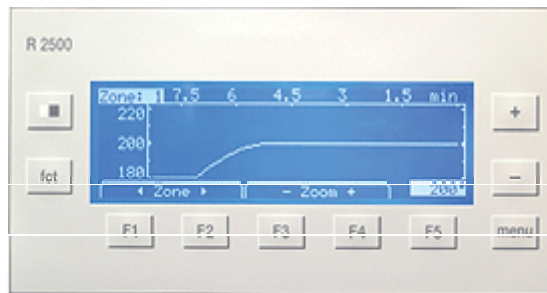

**F1 key:** ◀ Zone: Select zone  
**F2 key:** Zone ▶: Select zone

The actual value is always displayed symmetrically around the current setpoint.

**F3 key:** Zoom - Enlarge cutout based on current setpoint.  
Approximate display.  
**F2 key:** Zoom + Decrease cutout based on current setpoint.  
Precise display.

Window above "F5": Display of current actual value.

**menu key:** Return to Menu 2

**F4 key: Device status.**  
Display



**Device Status**

Device type : ID number

Adjustment lock : actual setting

CANopen \*) : Status display of fieldbus

Actual setpoint : Depends on contact k1

Parameter lock : - see "Operator lock" parameter  
- in interface operation: REMOTE

CANopen\*) : or "Ser. Interface"  
or "Profibus"

**menu key:** Return to Menu 2

**F5 key:** **Switch to Menu 1**

## 6. Parameter Lists

### 6.1 Menu 2, Controller Parameters; zone dependent (F1)

adjustable for each controller zone.

<b>Setpoint 1</b>	Adjustment range: Lower setpoint limitation ... Upper setpoint limitation	(ex works: 0°C)
<b>Setpoint 2</b>	off; Lower setpoint limitation ... Upper setpoint limitation Setpoint 2 is valid for all zones, if the external contact K1 is closed. Setpoint2 = Off: Setpoint1 is still valid, if contact K1 is closed.	(ex works: off)
<b>Rising ramp</b>	off; 0,1 ...99,9 °C/min. oder °F/min. 0,01...9,99 if range with dec.point selected	(ex works: off)
<b>Falling ramp</b>	off; 0,1 ...99,9 °C/min. or °F/min. 0,01...9,99 if range with dec.point selected	(ex works: off)

A programmed ramp is always activated when the setpoint is altered or when the mains supply is switched on. The ramp constructs itself out of the momentary process value and the pre-selected setpoint. The ramp can be activated for both setpoint1 and setpoint2. By programming the second setpoint accordingly a setpoint profile can be obtained (please see example below).

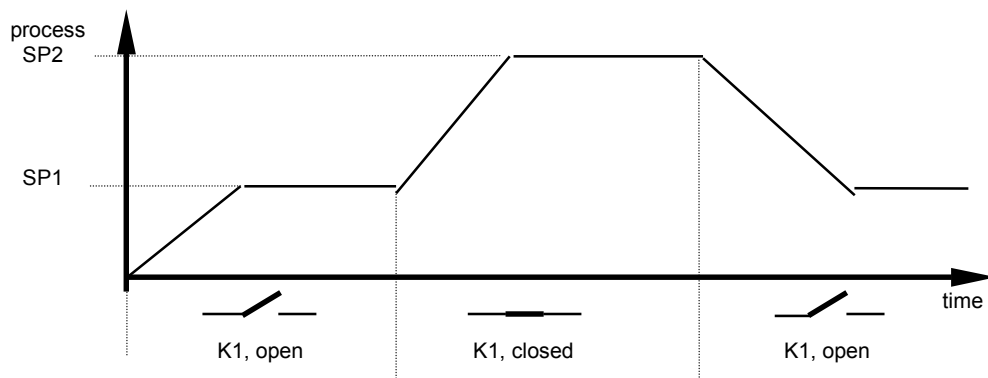

**Alarm value A1**, switching point  
(switches relay A1)

**Temperature monitoring:** alarm value adjustment

Signal contact: off= -200; -199... 199 °C/°F (ex works: off)

Limit comparator: off= 0; 1...199 °C/°F (ex works: off)

Limit contact: off= Measuring range, bottom end -1 (ex works: off)  
Adjustment: Measuring range, bottom end ... top end

**Heater current monitoring:** alarm value adjustment

Limit contact off=0; 0,0 ...99,9 A (ex works: off)

**Alarm value A2**, switching point  
(switches relay A2)

**Temperature monitoring:** alarm value adjustment

Signal contact: off= -200; -199... 199 °C/°F (ex works: Off)

Limit comparator: off= 0; 1...199 °C/°F (ex works: off)

Limit contact: off= Measuring range, bottom end -1 (ex works: off)  
Adjustment: Measuring range, bottom end ... top end

**Heater current monitoring:** alarm value adjustment

Limit contact off=0; 0,0 ...99,9 A (ex works: off)

<b>Output ratio limit</b> „heating or cooling“	0...100 % The limitation of the output ratio is only necessary, if: the heating or cooling energy supply is grossly overdimensioned compared to the power required, or to turn off a control output (setting = 0%). Under normal circumstances no limitation is needed (setting = 100%). The limitation becomes effective, when the controllers' calculated output ratio is greater than the maximum permissible (limited) ratio. <b>Warning!</b> The output ratio limitation does not work during autotune.	(ex works: 100)
<b>P (P-band)</b>	off; 0,1...100,0 % If „off“, go to parameter „Switch sensitivity“.	(ex works: 3,0)
<b>D (rate time)</b>	off; 1...200 secs.	(ex works: 30)
<b>I (reset time)</b>	off; 1...1000 secs. Normally the controller works using PD/I control action. This means, controlling without deviation and with practically no overshoot during start-up. The control action can be altered in its structure by making the following adjustments to the parameters: a. no control action, on-off (setting P = off) b. P-action (setting D and I = off) c. PD-action (setting I = off) d. PI-action (setting D = off) e. PD/I modified PID-action (set: P, D, I)	(ex works: 150)
<b>Cycle time</b>	0,5...240,0 secs. The switching frequency of the actuator can be determined by adjusting the cycle time. This is the total time needed for the controller to switch on and off once. a) Relay outputs: cycle time > 10 secs b) Bistable voltage outputs: cycle time 0,5...10 secs / optim. = 0,8secs.	(ex works: 10,0)
<b>Switch sensitivity</b>	Only if „P-band“ = off (on-off action, without feedback) off; 0,1... 80,0 °C off; 0,01... 8,00 °C (only ranges with dec. point)	(ex works: 0,1)

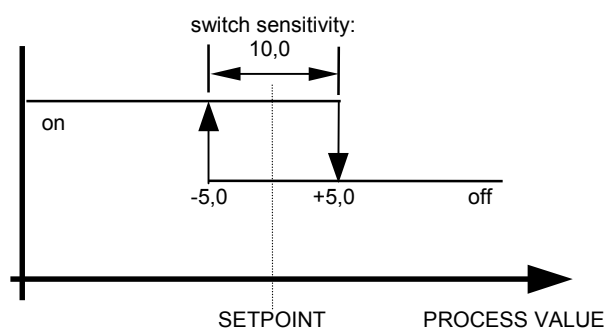

<b>Autotune</b> (selftuning algorithm)	off on	autotune / self tuning out of action autotune / self tuning on request ( one time)	(ex works: off)
---	-----------	---	-----------------

The tuning algorithm determines the characteristic values within the controlled process, and calculates the valid feedback parameters ( P,D,I ) and the cycle time ( = 0.3 x D ) of a PD/I-controller for a wide section of the range.

The autotune activates during start-up shortly before the setpoint is reached. The setpoint must amount to the least 5% of the total range.

If activated after the setpoint has already been reached, the temperature will first drop by approx. 5% of the total range, in order to detect the exact amplification of the process.

**Autotune activ**; indication see: menu 1 -> F4: Process Overview -> column „Info“ = Opt

The tuning algorithm can be activated at any time by selecting the **Autotune=on**. After having calculated the feedback parameters, the controller will lead the process value to the actual setpoint.

Selecting **Autotune=off** will stop the autotune-function.

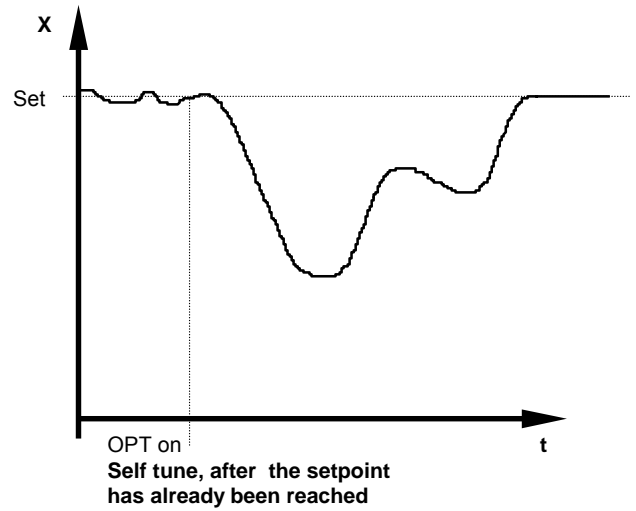
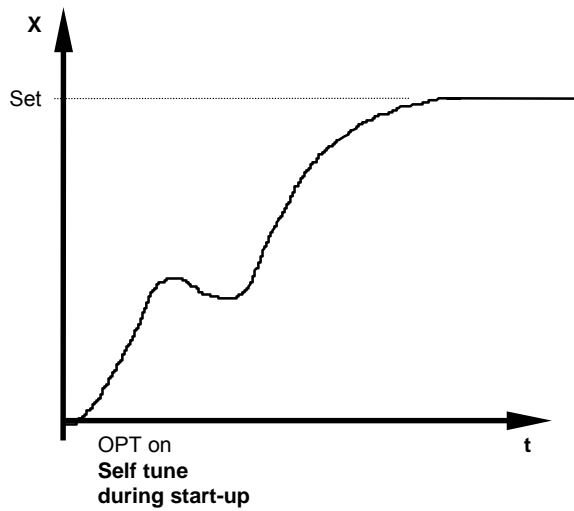

<b>Process offset</b>	-99 ... off ... 100 °C/°F -9,9 ... off ... 10,0 °C/°F	(ex works: off)
-----------------------	--	-----------------

This parameter serves to correct the input signal, e.g. for:  
 - the correction of a gradient between the measuring point and the sensor tip,  
 - the line resistance balancing of 2-line RTD (Pt100) sensors and  
 - correction of the control deviation when using P- or PD-action.  
 If for example the offset value is set to +5°C, then the real temperature measured by the sensor (when process is balanced) is 5°C less than the setpoint and the displayed process value.

<b>Zone on/off</b>	on off	Measuring- or controller zone activ Measuring- or controller zone switched off	(ex works: on)
--------------------	-----------	---	----------------

<b>Controller configuration</b>	2P h 2P c 2Pnc diSP	2-point controller: "heating-off" 2-point controller: "cooling-off" 2point-controller „cooling-off“ with non-linear cooling. Cooling action can be pre-selected with either linear or non-linear cooling response curve ( e.g. for vapour cooling). Zone works only as an indicator, no controller action	(ex works: 2P h)
---------------------------------	------------------------------	---	------------------

**Sensor selection**

P1 °C	Pt 100,	0,0 ... 99,9	°C	
P1 °F	Pt 100,	32 ... 212	°F	
P2 °C	Pt 100,	-100 ... 200	°C	
P2 °F	Pt 100,	-148 ... 392	°F	
P4 °C	Pt 100,	0...400	°C	(ex works)
P4 °F	Pt 100,	32...752	°F	
P8 °C	Pt 100,	0...800	°C	

or, if thermocouple has been selected:

L4 °C	T/C Fe-CuNi (L),	0...400	°C
L4 °F	T/C Fe-CuNi (L),	32...752	°F
L8 °C	T/C Fe-CuNi (L),	0...800	°C
J8 °C	T/C Fe-CuNi (J),	0...800	°C
n1 °C	T/C NiCr-Ni (K),	0...999	°C

**Take care:**

If the Sensor selection is changed, the following parameters will be set as follows and need to be re-adjusted:

Setpoint 1, Setpoint 2:	Setpoint limitation min.
Lower setpoint limitation:	Bottom range end
Higher setpoint limitation:	Top range end
Setpoint-ramp values:	off
Alarm values:	off
Process value offset:	off

**Setpoint limitation max.**

Highest adjustable setpoint value (ex works: 400°C)  
programming range: setpoint limitation min. ... top range

**Setpoint limitation min.**

Lowest adjustable setpoint value (ex works: 0°C)  
programming range: bottom range ... setpoint limitation max.

**Softstart-function,  
general**

**If you take the softstart-function, make sure that the instrument is equipped with bistable voltage (logic) outputs. This function is not allowed for instruments with relay-outputs ( in this case set Sst = off). Otherwise the relays will be damaged.**

**Softstart (general function):**

During the softstart the controllers' heating output response is limited to a pre-selected ratio, in order to achieve a slow baking out of high performance heat cartridges.

Simultaneously the output clock frequency is quadrupled. Once the process value reaches the softstart setpoint, it remains stable at this value for a pre-selected hold-duration time.

At the end of this period the process value rises to the valid setpoint.

This results in a slower, more regular heating period.

For this purpose the bistable voltage output must be taken, that actuates SSR relays.

If the softstart is active, the controllers' autotune function can't operated (E.Op).

If a setpoint-ramp has been programmed, the softstart has priority, and the ramp will only become active after the softstart has been completed.

The softstart only works,

- if the parameter „P-band“ is programmed > 0,1%.

- if the actual process value is lower than Softstart-setpoint – 5% of the selected measuring range.

It is possible, to select this function for each zone individually.

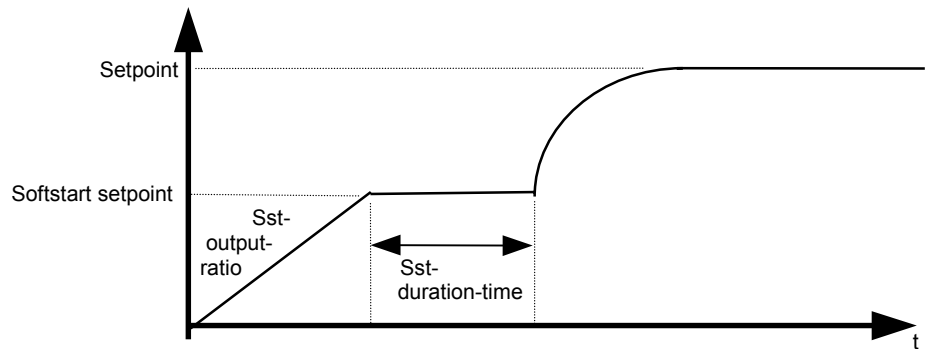

**Sst Softstart**  
Softstart function

off: Softstart function not active (ex works)  
Other Sst - parameters are not shown.  
on: Softstart function in action.  
The softstart function always runs, if the controller is switched on and / or if the actual temperature is below the softstart setpoint minus 5% of the range (e.g. range: 400°C -> 5%= 20°C).  
Adjust the following parameters.

**Sst output ratio**  
Softstart output ratio

10 ... 100%

**Sst setpoint**  
Softstart setpoint

range: setpoint min. .... setpoint max.

**Sst duration time**  
Softstart duration time

off; 0,1 ... 10,0 min.

## Output mode

cont Normal Controller mode. (ex works)  
Output ratio = 0% in case of sensor error (breakage).

auto In event of sensor break the controller automatically maintains the last valid output ratio as the actuating signal.

Process display: Error display „Er.H“ or „Er.L“.

Setpoint display: An „H“ is then displayed as the first digit in the setpoint display, followed by the valid output ratio. This ratio can be manually altered (like a setpoint). H99 = 100%.

Under the following circumstances, the output ratio will be 0%:

- if the output ratio at time of the sensor break was 100%.
- if the controller is working along a setpoint-ramp.
- if the control deviation was more than 0,25% of the total range at the time of sensor break.
- if the prop. band (P-band) = 0.
- if the softstart was active at the time of the sensor break.

A few seconds after the sensor break has been rectified, the controller returns to automatic operation and calculates the required output ratio.

An additional signal can be issued in the event of sensor break, if the alarm contacts are programmed accordingly.

man The controller now operates only as an actuator = manual mode. The control function (PID) is out of work.

Process display: Display of the actual process value.

Setpoint display: An „H“ is then displayed as the first digit in the setpoint display, followed by the valid output ratio. This ratio can be manually altered (like a setpoint). H99 = 100%.

## Copy to zone

The parameters, programmed in this zone, can be copied to any other zones with the same sensor type.

Select targeted zone number with the keys: + / - .

„All“ : copy to all other zones.

The data will be copied if another or the next zone has been selected or if the „F5 / enter“ - key has been pressed.

## 6.2 Menu 2, Device Parameters (F2)

general parameters, valid for the complete device functions.

### PT100(RTD) / TC

Sensor preselection (sensor mix)

- / x	all zones prepared for thermocouple (TC) - connection
2 / x	Zones 1 - 2 : RTD - connection; other zones: Thermocouple connection
4 / x	Zones 1 - 4 : RTD - connection; other zones: Thermocouple connection
6 / x	Zones 1 - 6 : RTD - connection; other zones: Thermocouple connection
8 / x	Zones 1 - 8 : RTD - connection; other zones: Thermocouple connection
10 / x	Zones 1 - 10: RTD - connection; other zones: Thermocouple connection
12 / x	Zones 1 - 12: RTD - connection; other zones: Thermocouple connection
14 / x	Zones 1 - 14: RTD - connection; other zones: Thermocouple connection
16 / -	all zones prepared for PT100(RTD) - connection

### Alarm configuration A1

(switches relay A1)

The selected configuration is effective for all control zones (collector contact).

The individual temperature alarms A1 of all zones are connected to the main, common contact A1. If a control zone indicates a fault (sensor short circuit / break ), the alarm output A1 is generally switched.

works)	alarm off	no alarm signalisation	conf. no.:	0 (ex
	signal contact	setpoint dependend: low - high	1	
	limit contact	process value dependend: low - high	2	
	limit comparator	setpoint dependend: low - high - low	3	
	signal contact	setpoint dependend: high - low	4	
	limit contact	process value dependend: high - low	5	
	limit comparator	setpoint dependend: high - low - high	6	
	limit comparator	with start-up suppression: low - high - low	7	
	heater current monitoring; limit contact:	low - high	8	
	heater current monitoring; limit contact:	high - low	9	

#### Please note:

In case of sensor error the alarms will react in the same way as range override. Care should be used to ensure, that the setpoints of the alarm contacts are programmed within the selected measuring range.

If a setpoint ramp has been programmed, the alarms that are relative to the setpoint (signal contact, limit comparator) follow the setpoint up the ramp.

The alarm contacts therefore do not offer protection against all types of plant breakdown. With this in mind, we recommend the use of a second, independent monitor unit.

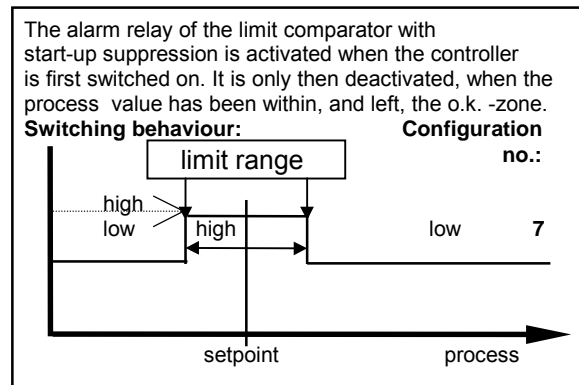
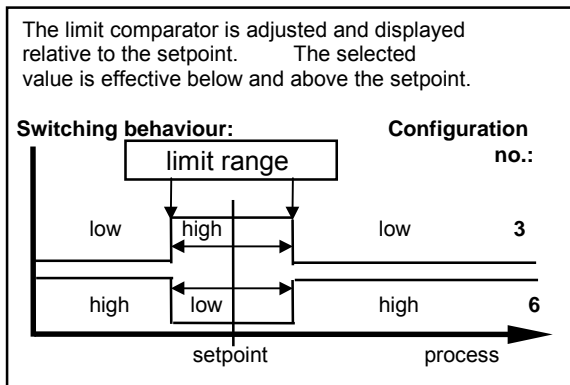
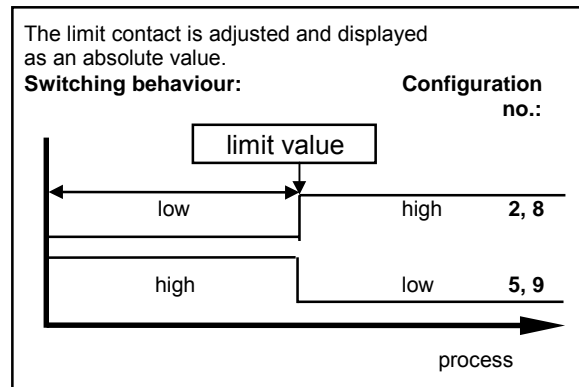
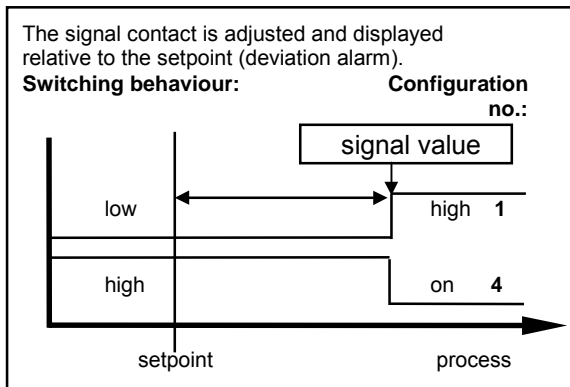

**Switching behaviour A1**  
Relay A1

direct high = Relay A1 "activated" (display-signalisation = 1)  
low = Relay A1 "not active" (display-signalisation = no)

invers high = Relay A1 "not activated" (display-signalisation = 1)  
low = Relay A1 "activated" (display-signalisation = no)

Signalisation of the relay-status, see:  
menu1 -> F3: Tendency Display -> Temperature Tendency- and Alarm Display  
Line AL1

**Alarm configuration A2**  
(switches relay A2)

The selected configuration is effective for all control zones (collector contact).  
The individual temperature alarms A2 of all zones are connected  
to the main, common contact A2. If a control zone indicates a fault (sensor short  
circuit / break ), the alarm output A2 is generally switched.

works)

alarm off	no alarm signalisation		conf. no.:	0 (ex
signal contact	setpoint dependent:	low - high	1	
limit contact	process value dependent:	low - high	2	
limit comparator	setpoint dependent:	low - high - low	3	
signal contact	setpoint dependent:	high - low	4	
limit contact	process value dependent:	high - low	5	
limit comparator	setpoint dependent:	high - low - high	6	
limit comparator	with start-up suppression:	low - high - low	7	
heater current monitoring; limit contact:		low - high	8	
heater current monitoring; limit contact:		high - low	9	

**Switching behaviour A2**  
Relay A2

direct high = Relay A2 "activated" (display-signalisation = 1)  
low = Relay A2 "not active" (display-signalisation = no)

invers high = Relay A2 "not activated" (display-signalisation = 1)  
low = Relay A2 "activated" (display-signalisation = no)

Signalisation of the relay-status, see:  
menu1 -> F3: Tendency Display -> Temperature Tendency- and Alarm Display  
Line AL2

## Heater current monitoring (Option)

The heater current monitoring function is valid for all connected control zones .  
The following parameters will only be displayed if the heater current monitoring system is activated as described below:

Select and configure:

Menu 2 -> F2: Device Parameters ->

- Heater current monitoring via relay A1: Set parameter „Alarm config. A1“ to conf. no. 8 or 9  
or

- Heater current monitoring via relay A2: Set parameter „Alarm config. A2“ to conf. no. 8 or 9

The heater current to be monitored, has to be programmed as an absolute value for relay A1 or relay A2.

Programming: Menu 2 -> F1: Controller Parameters -> „Alarm value A1“ or „Alarm value A2“.

Signalisation, see: Menu 1 -> F3: Tendency Display -> Temperature Tendency- and Alarm Display. Lines A1 or A2.

Please note:

If the supply voltage is low, the heater current has to be higher than the monitoring value. Otherwise the alarm signal will be activated.

If the heater current value falls below the monitoring value, an alarm signal (the relay switches) will be activated.

With the help of the parameter „Delay time“ it is possible to program a delay time for this.

When switching the power-on, the alarm signalisation will be suppressed until the heating current values for all zones has been scanned and verified.

<b>Current det.cycle</b>	1 ... 60 sec.	Time between the current measuring of two zones following each other. (ex works: 2 secs.)
Current detection cycle		

<b>Delay time A1</b>	5 steps adjustable (in sec.)	Adjustment and display in seconds.
If alarm relay A1 is selected for heater current monitoring.	Off= no delay time	The values are dependent on the current detection cycle time and the number of active controller zones.

<b>Delay time A2</b>	5 steps adjustable (in sec.)	Adjustment and display in seconds.
If alarm relay A2 is selected for heater current monitoring.	Off= no delay time	The values are dependent on the current detection cycle time and the number of active controller zones.

<b>Min. leak. current</b>	Off; 0,0...99,9 A	Adjustment of the allowed min. leakage current value.
Minimal leakage current value		The heater current will be monitored to detect circuits with an eventual leakage current (e.g. SSR damage).

SSR's (especially if they are combined with RC-combinations) normally have small leakage currents. Heaters also have small leakage currents.

The sum of the actual leakage current will be displayed as: act. curr =xx.x

If a permanent current is detected in one zone the alarm relay will be activated, the status will be displayed.

See menu 1 -> F4: Process Overview.

In column „Al.“ an „A“ will be displayed.

-> F3: Tendency Display.

In line A1 or A2 the warning „Permanent current detected“ will be displayed.

Current values below the programmed „Min. leak. current“ will be ignored.

Zones with a leakage current can be detected by observing the actual temperate process values.

### Technical data: Heater current monitoring

Current transformer 1:1000: (Type M2000)	Passive through current transformer with snap-in attachment for DIN rail mounting (EN 50022, 35mm). Connections to the controller: 2 x 6,3mm flat connectors.
---	--

Heater current detection and indication range:

0...max. 60,0A. Single-phase operation.

0...max. 99,9 A. Three-phase operation.

The sum of the current of all three phases of one controller zone will be monitored.

Variations of the power supply voltage have to be considered when the the alarm values are programmed.

**Adjustment lock**

- no parameters locked (ex works)
- only setpoint 1 free (adjustable) other parameters locked
- setp./alarm/ramp free setpoints, alarm values and ramp parameters adjustable
- all parameters locked
- remote Only if Profibus-interface is installed.

**Zones offset**

(Continuous numbering of the controller zones if more than 1 device is used)

- off; 1 - 83 Zones will be numbered with a preselected offset value.
- off: No offset preselection. (ex works)
- Zones numbering: 1 - 16
- 16: Zones numbering: 17 - 32

The following parameters are only valid, if the unit is equipped with a serial interface.

**RS232, RS485, 0/20mA.****Protocol preselection**

- standard ELOTECH protocol
- gateway Valid for InterBus-S via gateway M-IBS-5  
Only with RS 485-interface (Code-No.: 4).
- modbus in preparation

**Unit address**

- 1 .... 255 (ex works: 1)
- The computer addresses the unit/controller at this address.
- Each unit has its own address. With RS-485 it is possible to address 32 units.

**Data format**

- |     |               |           |                        |
|-----|---------------|-----------|------------------------|
| 7E1 | 7 data, even, | 1 stopbit |                        |
| 7o1 | 7 data, odd,  | 1 stopbit |                        |
| 7E2 | 7 data, even, | 2 stopbit |                        |
| 7o2 | 7 data, odd,  | 2 stopbit |                        |
| 7n2 | 7 data, none, | 2 stopbit |                        |
| 8E1 | 8 data, even, | 1 stopbit |                        |
| 8o1 | 8 data, odd,  | 1 stopbit |                        |
| 8n1 | 8 data, none, | 1 stopbit | InterBus-S via gateway |
| 8n2 | 8 data, none, | 2 stopbit |                        |

**Baud rate**

- off; 0,3 ... 9,6 kBaud (ex works: 9,6)
- The baud rate denotes the transmission rate at which one bit is transmitted.
- InterBus-S = 9,6 kBaud

- See:
- sep. interface description: ELOTECH – standard-protocol
  - sep. interface description: Gateway: M-IBS-5

The following parameters are only valid, if the unit is equipped with a **CAN interface**.

<b>Unit adress</b>	1 .... 127	(ex works: 1)
<b>Baud rate</b>	10, 20, 50, 100, 125, 250, 500k, 1000k Baud	(ex works: 20)
<b>CANopen-specification:</b>	CANopen Master: no CANopen Slave: yes Extended Boot-up: no Minimum Boot-up: yes COB ID Distribution: yes; default via SDO Node ID Distribution: no; via device keyboard No. of POD's: 0RX, 1TX PDO Modes: async. Variable PDO mapping: no Emergency message: yes Life guarding: yes No. of SDO's: 1RX, 1TX Device Profile: CiA DS-404	
<b>See:</b>	ELOTECH Object Dictionary ELOTECH Shortform Object Dictionary; Multizones controller CiA CANopen Devive Profile DS-404	

The following parameters are only valid, if the unit is equipped with a **PROFIBUS DP – interface**.

<b>Remote operation</b>	off (LOCAL) on	Controller operation via the keyboard. It is only possible to programm and operate the controller via the Profibus – interface.
<b>Device adress</b>	1 .... 125	
<b>Baud rate</b>	The baud rate will be detected and displayed automatically. It is not adjustable.  not detected. 12 n 12 MBaud 6 n 6 MBaud 3 n 3 MBaud 1,5 n 1,5 MBaud 500 500 kBaud 187,5 187,5 kBaud 93,75 93,75 kBaud 45,45 45,45 kBaud 19,2 19,2 kBaud (will not be supported) 9,6 9,6 kBaud (will not be supported)	
<b>See:</b>	ELOTECH - Profibus DP description	

<b>Sample time</b>	2,5s ... 10min.	See: Recorder function menu 1 -> F3: recorder function  Adjustment of the time difference between two temperature values. It is possible to store up to 200 temperature values. The overall time, wich can be monitored, will be displayed. <b>Note:</b> The sample time has to be shorter than the fastest changings of the actual temperature.
--------------------	-----------------	--

<b>Language</b>	english deutsch
-----------------	--------------------



## 7.3 Profibus- DP, general

The controller series R2500 can be equipped with a Profibus-DP-interface acc. EN 50170.

**It is essential, that one has well experience in installing a Profibus-device.**

The communication is always controlled by the Profibus-master. The control device is always the „slave“. All process-, parameter- and configuration datas can be transferred.

<b>Interface:</b>	RS485 Twisted pair 2-wire connection. See EN 50170, Chapt. 2
<b>Network-Topology:</b>	Linear bussystem with activ bus termination on both ends. Spot lines are possible (depending of the used cable type): 3-12Mbit/sec. = max. lenght: 1,5m 1,5Mbit/sec. = max. lenght: 6,5m

### **Baud rate and wiring lenght (without repeater):**

The baud rate will be detected by the Profibus-master automatically.  
The maximal wiring lenght depends of the used baud rate.

Baud rate	Max. wiring lenght
93,745 kbit/sec.	1200m
187,5 kbit/sec.	1000m
500 kbit/sec.	400m
1,5 Mbit/sec.	200m
3 – 12 Mbit/sec.	100m

### **Connections:**

The terminals (signals) VP and GND only are to be used to connect the external terminating resistors.  
There are no further connections allowed.

Plug-in terminals:	<b>90</b>	GND
	<b>91</b>	VP +5V
	<b>92</b>	CNTR
	<b>93</b>	RxTxP
	<b>94</b>	RxTxN

### **Device Address:**

Each device has it's own adress (1...125), wich will be programmed via parameter „Device adress“. If a new adress number has been programmed, please switch the device off and on again, to overtake the new adress.

There are up to 32 device addresses in one segment programable.

With the help of a repeater up to 127 devices can be connected.

The single controller zones are called up within the protocol.

<b>Special:</b>	- Configuration channel für reading and writing of all available parameters. - Configurable process data moduls. - Diagnostic warnings, to detect sensor- and/or system errors. - Easy connection to IPC's or PLC's.
-----------------	---

### **Informations about the Profibus-communication: see menu2 -> F4: Device Status:**

Line „Profibus“:	<b>no connection:</b>	Profibus not connected or master not activ.
	<b>wait param:</b>	Master detected – Device expects parameter
	<b>data exchange:</b>	Data Exchange Modus
	<b>Error:</b>	Profibus-system error

### **Important:**

Parameter „remote“ has to be set to „on“. Otherwise it is not possible to write datas into the device.

### **See:**

**Elotech-Discription and Data transfer Profibus-DP**

## 8. Technical Data

<b>Input RTD, Pt 100 (DIN):</b>	2 - or 3 - wire connection possible. Built-in protection against sensor breakage and short circuit. Max. permissible line resistance by 3-wire connection: 80 Ohms Sensor current: $\leq 1$ mA Calibration accuracy: $\leq 0,2$ % Linear error: $\leq 0,2$ % Influence of the ambient temperature: $\leq 0,01$ % / K
<b>Input Thermocouple:</b>	Built-in internal compensation point and protection against sensor breakage and incorrect polarity. Re-calibration not required for a line resistance of up to 50 Ohms. Calibration accuracy: $\leq 0,25$ % Linear error: $\leq 0,2$ % Influence of the ambient temperature: $\leq 0,01$ % / K
<b>Setpoint selection:</b>	Ext. potential-free contact, switching voltage appr. 24 V DC, max. 1 mA. Selection between Setpoint1 and Setpoint2 valid for all zones.
<b>Control outputs OUT 1 ... 16:</b>	Bist. voltage signal, 0/18 V DC, max. 10 mA, short-circuit proof or Relay, max. 250 VAC, max. 3 A (cos-phi = 1)
<b>Alarm outputs A1 and A2:</b>	Relay, max. 250 VAC, max. 3 A (cos-phi = 1)
<b>LCD-Display:</b>	Blue STN-display with permanent, white LED-background lightening Graphik: 240 x 64 pixel Text: 8 lines with 40 symbols each
<b>Ser. interface (option):</b>	RS232 or RS485 or 0/20mA (Protocol: ELOTECH-standard) CANopen, CiA Device Profile DS-404 Modbus Profibus DP, acc. EN 50170
<b>Data protection:</b>	EAROM
<b>CE – mark:</b>	Tested according to 89 / 336 / EWG EN 50081-2, EN 50082-2 Electr. safety: EN 61010
<b>Power supply:</b>	Standard: 230 V AC, $\pm 10$ %, 48...62 Hz, appr. 10VA
<b>Connections:</b>	Screw terminals, Protection mode IP 20 (DIN 40050), Insulation class C
<b>Permissible operating conditions:</b>	Operating temperature: 0...50 °C / 32...122 °F Storage temperature: -30...70 °C / -22...158 °F Climate class: KWF DIN 40040; equivalent to annual average max. 75 % rel. humidity, no condensation
<b>Casing:</b>	Format: 194 x 98 mm (DIN 43700), installation depth 122 mm Panel cutout: 186 +1,1 mm x 92 +0,8 mm Material: Noryl, self-extinguishing, non-drip, UL 94-V1 Protection mode: IP 20 (DIN 40050), IP 50 front side
<b>Weight:</b>	app. 800 g

Subject to technical improvements!

## 9. Error displays

Display	Cause	Possible remedy
LOC	Parameter has been locked	Unlock, if need be. Menu 1 -> F2: Device parameters -> Adjustment lock
LOC EXT	Parameter has been locked by contact K2	Open contact K2
Er.H	Top range end has been exceeded, sensor defect	Check sensor and cable
Er.L	Bottom range end has been exceeded, sensor defect	Check sensor and cable
E.Op	Self tuning error	Extinguish error signal by pressing the „Er.Quit (F3)“ -key. Check the self tuning conditions and restart.
E.Sy	System error	Extinguish error signal by pressing the „Er.Quit (F3)“ -key. Check all parameters. If the error signal continues please send the controller for examination.
E.O	System error	Please send the controller for examination.
REMO	Manual adjusting or programming of parameters not possible. Remote-status. Profibus-DP	Set parameter „Adjustment lock“ : off. Menu 1 -> F2: Device Parameters -> Adjustment lock
KONF	Alarm configuration: off No alarm value adjustable.	Set „Alarm configuration“ Menu 1 -> F2: Device Parameters -> Alarm config.

## 10. Installation Instructions

Make certain that the devices described here are used only for the intended purpose.

They are intended for installation in control panels.

The controller must be installed so that it is protected against impermissible humidity and severe contamination.

In addition, make sure that the permitted ambient temperature is not exceeded.

**The electrical connections must be made according to the relevant locally applicable regulations and by properly qualified personnel.**

If using a thermocouple sensor, the compensation cables must be laid directly to the controller terminals.

Transducers must be connected only in compliance with the programmed range.

Transducer cables and signal lines (e.g. logic or linear voltage outputs) must be laid physically separated from control lines and mains voltage supply cables (power cables).

Spatial separation between controller and inductive loads is recommended.

Interference from contactor coils must be suppressed by connecting adapted RC-combinations parallel to the coils.

Control circuits (e.g. for contactors) should not be connected to the mains power supply terminals of the controller.

### IMPORTANT:

**Before operation, the unit must be configured for its intended purpose under an expert guidance.**

(e.g. controller type, sensor type and range, alarm adjustment etc.)

Please see „Configuration Level“.

---

**ELOTECH** Industrieelektronik GmbH

Verbindungstr. 27

D - 40723 HILDEN, Germany

Tel.: 0049 2103 23055 Fax: 0049 2103 23057

www.elotech.de

E-mail: elotech@t-online.de

# The Microprocessor Based Multizone Controller System with LCD-Display



**ELOTECH**  
INDUSTRIELELEKTRONIK GMBH

Type Code: R 2500

Format 194 x 98 mm (panell outcut acc. to 1/2-DIN)

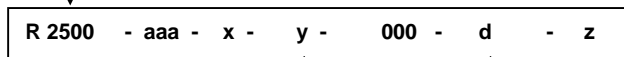

- 1: Power supply : 230 V AC
- 2: Power supply : 115 V AC
- 3: Power supply : 24 V AC
- 5: Power supply : 24 V DC

- 0: without ser. interface
- 2: RS232-C interface. Data-protocol: ELOTECH -standard
- 4: RS485 interface. Data-protocol: ELOTECH -standard  
InterBus-S via gateway M-IBS-5
- 5: 0/20mA interface. Data-protocol: ELOTECH -standard
- 7: CANopen interface, CiA Device Profile DS-404
- 9: Profibus DP, EN50170

- 0: Standard
- 5: with heater current monitoring. Controller outputs: only bistable voltage

- 0: Sensor programmable: Pt100, 2+3-wire. Type L, Type J, Type K.
- 1: Only for type A26-1: Sensor: Pt100, only 2-wire-connection possible

<b>821</b>	8 - Zones 2-point controller;	Control outputs: relay
<b>826</b>	8 - Zones 2-point controller;	Control outputs: bistable voltage. Com.: -
<b>831</b>	8 - Zones 2- or 3-point controller;	Control outputs: „heating“: relay; „cooling“: relay
<b>836</b>	8 - Zones 2- or 3-point controller;	Control outputs: „heating“: bist. voltage; „cooling“: bist. voltage. Com.: -
<b>837</b>	8 - Zones 2- or 3-point controller;	Control outputs: „heating“: bist. voltage. Com.: -; „cooling“: relay
<b>A21</b>	10 - Zones 2-point controller;	Control outputs: relay
<b>A26</b>	10 - Zones 2-point controller;	Control outputs: bistable voltage. Com.: -
<b>C21</b>	12 - Zones 2-point controller;	Control outputs: relay
<b>C26</b>	12 - Zones 2-point controller;	Control outputs: bistable voltage. Com.: -
<b>E21</b>	16 - Zones 2-point controller;	Control outputs: relay
<b>E26</b>	16 - Zones 2-point controller;	Control outputs: bistable voltage. Com.: -

2-point controller = „heat-only“ or „cool-only“ programmable. 3-point controller = „heating-off-cooling“