

MOVITRAC[®] 0500 Frequency Inverters

Operating Instructions

Edition 01/97

CE

0922 3916 / 0197



SEW
EURODRIVE

Inverter Design

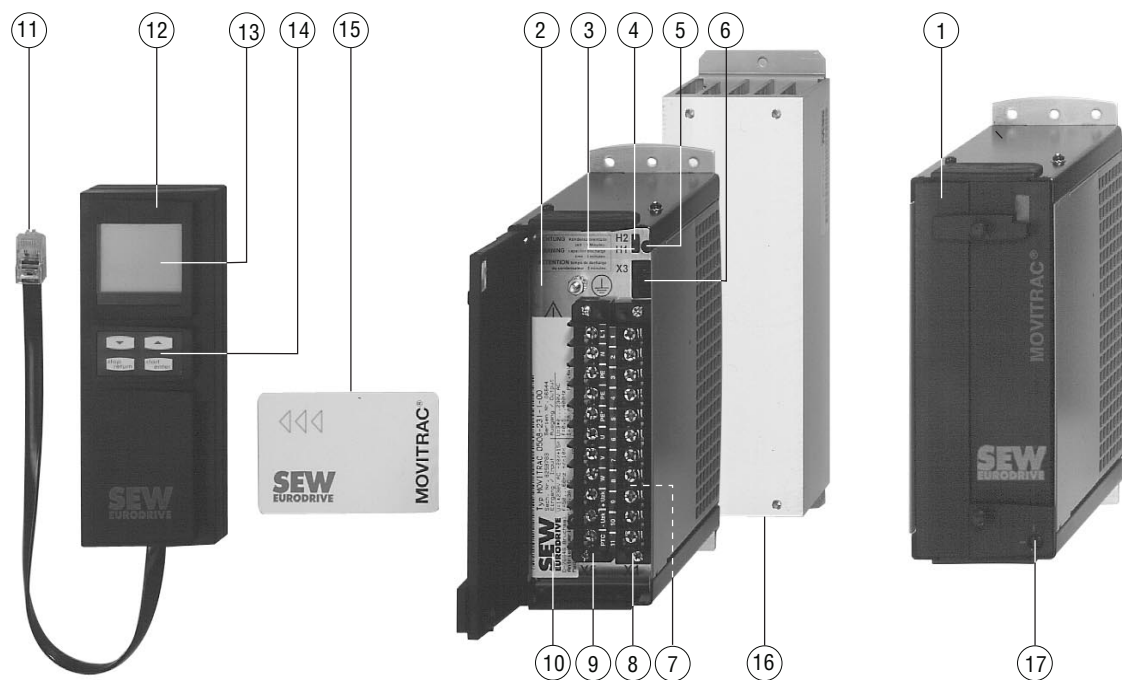

Fig. 1: MOVITRAC® 0500 with FBG 01 keypad and FKS 01 heat sink

00401BXX

- 1 MOVITRAC® 0500 frequency inverter - basic unit with cover closed
- 2 MOVITRAC® 0500 frequency inverter - basic unit with cover removed
- 3 LED H1 (red) operating display / fault signal
- 4 LED H2 (green) operating display
- 5 Poti P1, internal setpoint potentiometer
- 6 Socket X3 for FBG 01 keypad
- 7 Jumper strip X2 (not visible), located underneath terminal strip X1
- 8 Terminal strip X1 - electronic/control connections
- 9 Terminal strip X5 - power section
- 10 Nameplate (bar code section not visible)
- 11 Connecting cable for the FBG 01 keypad with connector
- 12 FBG 01 keypad
- 13 LCD display with 140 characters
- 14 Membrane keypad
- 15 ParaCard PAC 01
- 16 FKS 01 heat sink
- 17 Cover interlock of the MOVITRAC® 0500 basic unit

	Page
Inverter design	2
1 General Notes	4
2 Safety Notes	6
3 Electrical Installation	7
3.1 Installation Instructions	7
3.2 EMC-compliant installation	8
3.3 Wiring diagram for the basic unit	9
3.4 Functional description of the basic unit terminals	9
3.5 Brake rectifier connection	10
4 Commissioning	11
4.1 Condensed commissioning instructions for standard applications	11
4.2 Operation with FBG 01 keypad	12
4.2.1 Connection and operating displays of the FBG 01 keypad	12
4.2.2 Menu structure	13
4.2.3 Manual operation / motorized potentiometer	15
4.3 Setting the signal mode for FSINA and SOUTA	16
4.4 Complete parameter list	17
4.4.1 Menu branch VAL, display parameters	17
4.4.2 Menu branch PARA, adjustable parameters	18
5 Operation and Service	20
5.1 Operating displays	20
5.2 Operating conditions / Overload condition	20
5.3 Fault information	21
5.4 SEW Electronics Service	22
6 Technical Data	23
6.1 Basic units	23
6.2 BRC 03 brake chopper with integral braking resistor	25
6.3 NF...-231 input filter	25
After-Sales and Spare Parts Service	26

For further technical information as well as project planning notes please refer to the MOVITRAC® 0500 Frequency Inverter Catalogue, publication no. 09223819.



Check the inverter for packaging damage as soon as you receive it.

Inform the carrier of any packaging damage immediately.

A requirement of fault-free operation and fulfilment of any rights to claim under guarantee is that these instructions and remarks are followed. **Therefore read these instructions carefully before you start working with the unit.**

These instructions also contain important **service instructions**. They should therefore be kept **near the inverter**.

Always follow the relevant **safety instructions and warnings**. They are marked as follows:

	Electrical hazard , e.g. when working on live equipment
	Mechanical hazard , e.g. when working on hoists.
	Important instructions for safe and fault-free operation.

Cross-references to other sections or publications are indicated by →.

Each unit is manufactured and tested to current SEW-EURODRIVE technical specifications.

The manufacturer **reserves the right to make alterations to the technical data and design** which serve the cause of technical progress.

Storage instructions:

Permissible storage temperature:	-25°C...+70°C
Permissible humidity:	No restrictions during storage. On commissioning the unit must be free of condensation.
Extended storage:	Connect the unit to the power supply for at least 5 minutes every 2 years. Failing that the service life of the unit may be reduced.

Disposal (please observe the applicable waste disposal regulations):



Depending on the material they are made of, unit components are to be disposed of in accordance with the applicable waste disposal regulations for:
electronics scrap (pcbs), plastic material (housing), sheet metal, copper, etc.

Name plate

Example:



VDE 0558

	Typ MOVITRAC 0508-231-1-00		
	Sach. Nr. 8258783	Serien Nr. 15429	
	Eingang / Input	Ausgang / Output	
	U=1*230V AC -20%+15%	U=3*0...230V AC	
D-76646 Bruchsal	f=50...60Hz +/-10%	f=0,5...400Hz	
Antriebsumrichter	I=6,3A AC	I=3,2A AC	P=1,4kVA
Made in Germany	T=0...40 C	IP20	Lastart M

00423AXX

CE Mark:

MOVITRAC® 0500 frequency inverters conform with Low Voltage Directive 73/23/EEC and if installed in compliance with EMC regulations (→ Sec. 3.2) with EMC Directive 89/336/EEC.

Type designation

Example:

MOVITRAC® 0504 - 231 - 1 - 00

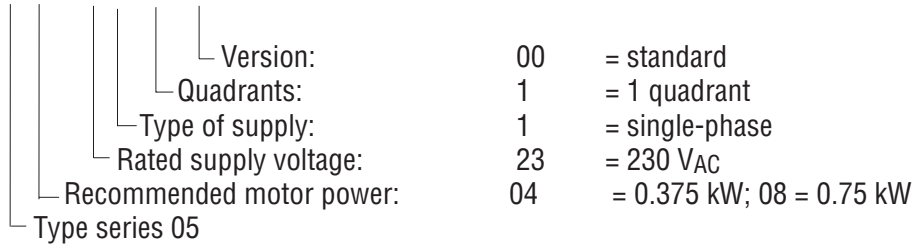



- **Installation, commissioning and servicing** of the inverter may only be performed by **qualified electrical personal** with the relevant training in accident prevention, in compliance with the valid regulations (e.g. EN 60204, VBG 4, DIN VDE 0100/0113/0160).
- When **installing** and **commissioning** the motor and brake, **the relevant instructions must be observed!**
- Before removing the front cover, the inverter must be disconnected from the supply. **Dangerous voltages** can remain present for **up to 2 minutes after the unit has been disconnected from the supply.**
- **When the inverter cover is removed** the inverter has enclosure **IP 00**. **Dangerous voltages** are present. During operation, the unit must be kept closed.
- When **switched on**, **dangerous currents** are present on the **output terminals** and the **cables and motor terminals** connected to them. This is also the case when the inverter is inhibited and the motor is not running.
- When the **operating displays H1 and H2** or any of the other status indicators **go out** this **does not mean** that the inverter is disconnected from the supply and is **de-energized**.
- **Protective measures** and **equipment** must be chosen according to the **applicable standards** (e.g. DIN VDE 0100 Part 410 / DIN VDE 0113 Part 1 and EN 60204 / DIN VDE 0160).
- Necessary protective measure: inverter must be earthed
Necessary protective equipment: overcurrent protection (fuses).
- By taking appropriate measures (e.g. removing the electronics terminal block), **ensure** that the connected **motor does not start by itself** when the inverter is **connected to the power supply**.
- Internal safety functions in the inverter or mechanical blocking can result in the motor **not running**. Remedying the cause of the fault or resetting the inverter can cause the **drive to start up by itself**. If this is **not admissible** for the machine being driven for safety reasons, the inverter should be **disconnected from the supply** before remedying the fault. Furthermore the **“72 START = 1 (AUTOSTART)”** function **must not be activated** in these cases.

The safety instructions (→Sec. 2, P. 6) must be strictly observed during the electrical installation!



3.1 Installation instructions

- Run **power cables** and **electronic leads** in **separate cable ducts**.
- **Power cable:** based on the input current I_{mains} at rated load (Data →Sec. 6).
- **Motor cable:** based on output rated current I_N (Data →Sec. 6).
- The **input fuses** must be installed at the beginning of the power cable, directly after the busbar junction (Wiring diagram → Sec. 3.3: F11).
- An **earth leakage circuit-breaker** is **not permissible** as the **sole protection device**. **Leakage currents > 3.5 mA** can occur in normal inverter operation.
- **Alternate operation of two motors from one inverter:** a changeover contactor must be provided for each of the two motor cables. **Changeover contactors may only be actuated when the inverter is inhibited!**
- Only an **inductive/resistive load (motor)** may be connected at the **inverter output**, no capacitive load!
- For **jogging**, use the commands clockwise STR / counterclockwise STL.
The **mains contactor K 11 must not be used for jogging**, but only for switching the inverter on and off!
- **Recommendation:** after power-down, wait minimum 30s before powering the inverter up again!
- The **binary** and **analogue outputs** are **isolated** by optocouplers. However, they are neither **short-circuit-proof nor external-voltage-proof** and can be destroyed by short-circuits or if an **external voltage** source is connected!
- **Brake chopper:** Loop in NC contact (TL. 7/8) in inverter power supply line (Connection →Se. 3.3). Cross-section based on the inverter rated current (Data → Sec. 6). **Under rated conditions supply leads to the brake chopper carry high DC voltages (approx. 500V).**
- Observe **allocation table for input filters** and MOVITRAC® types (→ Sec. 3.2)!



3.2 EMC-compliant installation

When installed in accordance with the instructions for EMC-compliant installation MOVITRAC® 0500 inverters meet the requirements for compliance with EMC Directive 89/336/EEC.

Interference immunity:

MOVITRAC®0500 frequency inverters comply with all the immunity requirements of EN 50082-2. In combination with shielded leads even more stringent levels than those stipulated in the standard are met.

Interference emission:

Higher levels of interference are permitted for industrial environments. In an industrial environment, one or several of the below listed measures may be done without, depending on the supply system specifications and the specifics of the installation.

To meet emission limits for the residential commercial and light industrial environment (class B limit to EN 55011) we recommend the following measures:

- Connect an appropriate NF...-... input filter on the line side.
 - MOVITRAC® 0504-231-1-00 → NF005-231 input filter
 - MOVITRAC® 0508-231-1-00 → NF008-231 input filter
 - Mount the NF.. input filter close to the corresponding MOVITRAC® 0500, but outside the minimum ventilation space required.
 - Keep the connecting lead between the input filter and the MOVITRAC® 0500 as short as possible: a maximum lead length of 400 mm is permissible. Unshielded, twisted-conductor leads are satisfactory.
- Provide the input filter and the MOVITRAC® 0500 with an earth which is effective at RF, i.e.
 - Wide-area metallic contact between the inverter housing and ground, for instance with the sheet metal of the switch cabinet housing.
- Shield all leads apart from the power cable.
 - Laying the cables in separate, earthed metal ducts or conduits is also effective as a shield.
 - The shield must be earthed by the most direct possible route, with a wide-area contact to ground at both ends. If necessary, then one end may be earthed via an interference suppression capacitor to prevent earth loops. Alternatively, use double-shielded cable with the outer shield earthed at the MOVITRAC® and the inner shield at the other end.

3.3 Wiring diagram for the basic unit

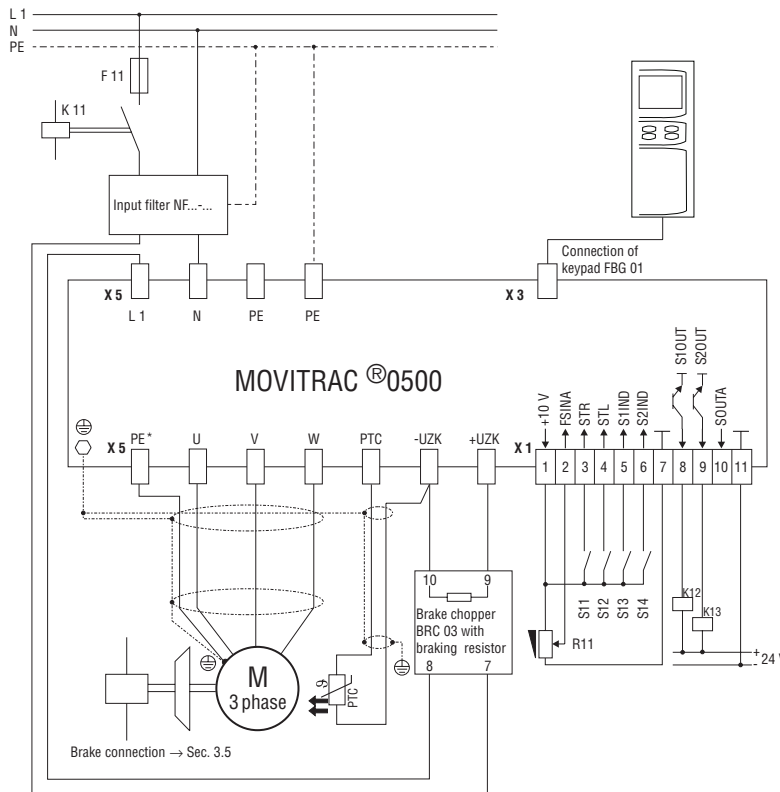

Fig. 2: EMC-compliant installation in residential areas (to class B limit)

00402BEN

3.4 Functional description of the basic unit terminals

Terminal	Code	Function
X1 1	UR	Reference voltage +10 V short-circuit-proof, current rating $I_{max} = 15 \text{ mA}$
2	FSINA	Analogue input frequency setpoint, input mode selectable (via jumper J1/J2 and PARA 04 FFSEL): 0...10 V / 2...10 V / 0...20 mA / 4...20 mA
3	STR	Binary input START CW: "0" = 0...2 V / "1" = 8...30 V
4	STL	Binary input START CCW: "0" = 0...2 V / "1" = 8...30 V
5	S1IND	Binary input 1: 0...2 V "1" = 8...30 V selectable fixed frequencies: 1/2/3 +
6	S2IND	Binary input 2: (PARA 20/23/24/27)
7	Ground	Jumpered with X1:11 internally
8	S1OUT	Binary output 1 $I_{max} = 50 \text{ mA}$ Important: not short-circuit-proof, do not apply external source voltage! Control functions (PARA 62/63 0...10): 0 = no function / 1 = collective fault / 2 = output voltage / 3 = CCW / 4 = CW / 5 = motor at rest / 6 = setpoint reached / 7 = frequency limit / 8 = current limit / 9 = brake chopper active / 10 = disconnection on faults
9	S2OUT	Binary output 2 $I_{max} = 50 \text{ mA}$
10	SOUTA	Analog / binary output $I_{max} = 2 \text{ mA}$ (analog) $I_{max} = 15 \text{ mA}$ (binary) Important: not short-circuit-proof, do not apply external source voltage! Control functions (PARA 61 0...7): 0 = no function / 1 = output frequency analog or PWM / 2 = brake chopper active / 3 = 6 times the output freq. / 4 = apparent current / 5 = active current / 6 = active power / 7 = cannot be activated.
11	Ground	Jumpered with X1:7 internally
X3		Connection of FBG 01 keypad
X5 L1, N, PE		Connection to the supply 1 x 230 V _{AC}
U, V, W, PE*		Motor connection
+V _{DClink} / -V _{DClink}		BRC 03 brake chopper connection including braking resistor
V _{DClink} / PTC		PTC thermistor connection, if no PTC thermistor is used, jumper terminals (default condition)!
PE*		Shield connection



3.5 Brake rectifier connection

The brake rectifier must have its own power supply lead, supply of the brake rectifier from the motor voltage is not permitted!

Basic circuit diagram: AC squirrel-cage motor with brake rectifiers BG/BGE via brake relay K1 and brake contactor K12.

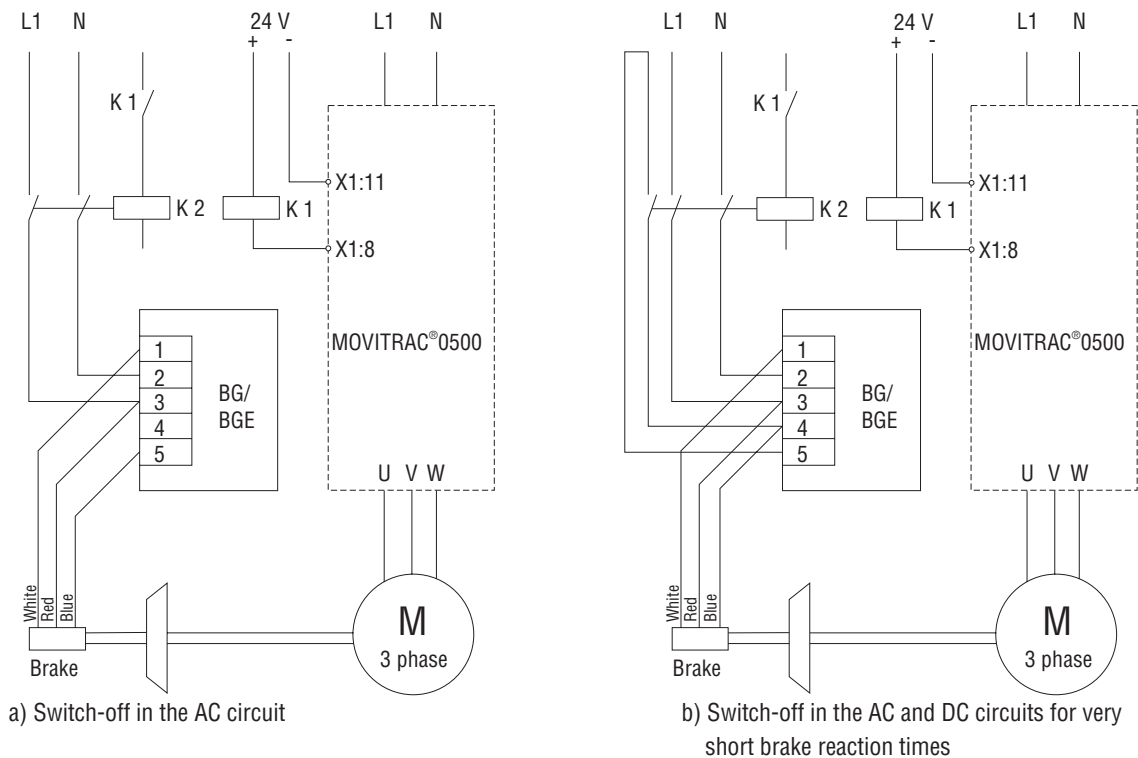

Fig. 3: Brake circuits

00403AEN

Binary output X1:8 or X1:9 “S_OUT” can be used to control the brake if programmed accordingly (parameter PARA 62/63 = “2”). For brake control an external 24 V supply is necessary.

The binary output drives an external brake relay K1 (24 V / 1.2 W / **max. 50 mA**). This relay controls the brake via a brake contactor K2. The brake must be actuated through the inverter output signal and **not via PLC!**

When the brake rectifier is installed in the switch cabinet follow the instructions for EMC-compliant installation contained in the installation instructions for “AC Squirrel-Cage and Single-Phase Motors, ...”.

The safety instructions (→ Sec. 2, P. 6) must be strictly observed during commissioning!



4.1 Condensed commissioning instructions for standard applications (FBG 01 keypad not required)

1. **Check installation** (connection to the supply 1 x 200...240 V_{AC}, motor voltage 3 x 200...240 V_{AC}).
2. **Connect setpoint input** 0...10V to X1:2 (FSINA): setpoint input via setpoint potentiometer (4.7...10 kΩ), potentiometer connection to X1:1 (+10V) and X1:7 (⊥) (wiring diagram → Sec. 3.3), or via external setpoint source or **selection** of internal **fixed setpoints** FF2, FF3 or FF4 via X1:5 (S1IND) / X1:6 (S2IND).
0...2V = "0" / 8...30V = "1".

S1IND	S2IND	Function	Factory setting
"0"	"0"	FSINA active	0...50Hz
"1"	"0"	FF2 fixed frequency active	3Hz (5Hz)
"0"	"1"	FF3 fixed frequency active	15Hz
"1"	"1"	FF4 fixed frequency active	30Hz

3. **Before you connect the inverter to the supply**, make sure that **no direction of rotation signal** is applied to the unit, i.e. X1:3 (STR) and X1:4 (STL) = "0".
4. **Connect the inverter to the supply.**
5. **Start the drive** in the direction of rotation you require: X1:3 (STR) or X1:4 (STL) = "1".
The drive will start if **setpoint input** ≥ 0.1 V (≥ 0.5 Hz) or one of the **fixed setpoints is selected**.
Important: if STR and STL = "1" **Stop** with brake ramp 33 RDEC1 or 35 RDEC2.
6. **Check the direction of rotation** of the inverter when **starting**
(Correct if necessary: switch off and change over motor phases).
7. **If the drive does not start** and LED H1 lights up red (no fault), **repeat start command** by setting X1:3 (STR) or X1:4 (STL) to "0" and then to "1" again.
8. **To reverse**, change over "0" and "1" on X1:3 (STR) and X1:4 (STL).
9. **To adjust the speed**, change the setpoint input on X1:2 (FSINA).
0...10 V setpoint input \triangleq 0...50 Hz frequency input (factory setting) or select a different fixed frequency.



The LED displays indicate the following:

H1 (red)	H2 (green)	Indication
OFF	OFF	Mains supply OFF
ON	OFF	Mains supply ON, inverter is ready for operation
OFF	ON	Inverter started
ON	ON	Inverter started and overload protection active
FLASHING	OFF	Fault indication by inverter (for fault information details → Sec. 5.3)

4.2 Operation with FBG 01 keypad

4.2.1 Connection and operating displays of the FBG 01 keypad

The MOVITRAC® 0500 basic unit comes without keypad. The optional FBG 01 keypad can be used to display and adjust the inverter parameters.

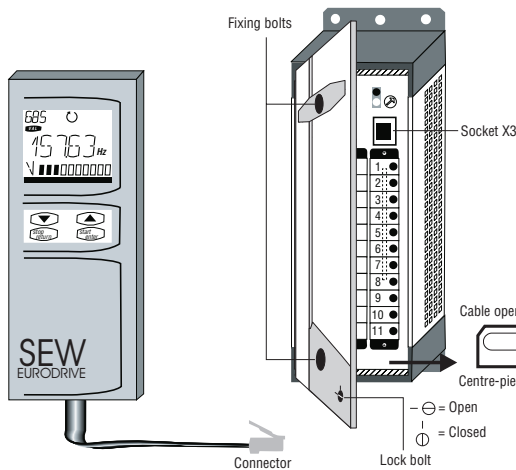

- Disconnect the inverter from the supply and wait for 2 minutes!
- Turn the interlock to open the inverter cover and remove lower cable gland.
- Take out perforated centre piece from cable gland (press to take out).
- Pull through FBG 01 connecting cable.
- Plug connector into socket X3 of the basic until it snaps into place.
- Re-insert cable gland and close cover.
- Position FBG 01 onto the two pins on the inverter cover and pull down until it snaps into place.
- To remove the FBG 01 again: push up and pull off forwards.

Fig. 4: FBG 01 connection

00407AEN

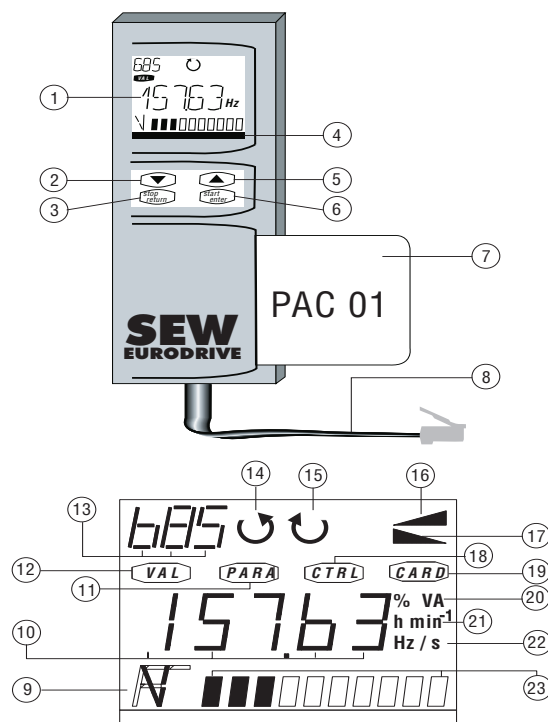

- 1 LCD display
- 2 Arrow key [down]
- 3 Key [Stop/Return]
- 4 Labelling field for bar graph display
- 5 Arrow key [up]
- 6 Key [Start/Enter]
- 7 Optional ParaCard PAC 01
- 8 Connecting cable FBG 01 - inverter
- 9 Dimension for bar graph display
- 10 5-digit actual value and setpoint indication
- 11 PARA menu branch for parameter adjustment
- 12 VAL menu branch for display values
- 13 3-digit display, actual values/parameter numbers
- 14 CCW direction of rotation
- 15 CW direction of rotation
- 16 Acceleration ramp
- 17 Deceleration ramp
- 18 CTRL menu branch for manual operation
- 19 CARD menu branch for reading/saving with PAC 01
- 20, 21, 22 Dimension for 5-digit display
- 23 Bar graph display

Fig. 5: FBG 01 displays

00406AXX

4.2.2 Menu structure

FBG 01 operation:

Arrow keys Are used to select menu branches/parameters and to edit parameters.

Press once	→	moves to next menu branch or parameter or effects smallest possible change in value.
Keep pressed	→	scrolls automatically.
Press both keys briefly →		resets parameter to factory setting.

[Start/Enter]

- Calls up menu branches or parameters.
- Confirms and saves changes.
- Enquires actual values.

[Stop/Return]

- Exits menu branches or parameters.
- Cancels changes.

The menu is structured as follows:

- **VAL** = display values
- **PARA** = adjustable parameters
In parameter 01 MODE (operating mode) three operating modes can be selected. The higher level comprises the parameters of the lower level(s).
 - 1st level **User menu with the most important parameters for commissioning (mode 0/1/4)**
 - 2nd level **Detailed parameter menu (mode 2)**
 - 3rd level **Extended parameter menu (fault memory and MAXF)**
- **CTRL** = inverter control via FBG 01 (manual operation/motorized potentiometer)
- **CARD** = copying parameter values with ParaCard PAC 01

The four menu branches:

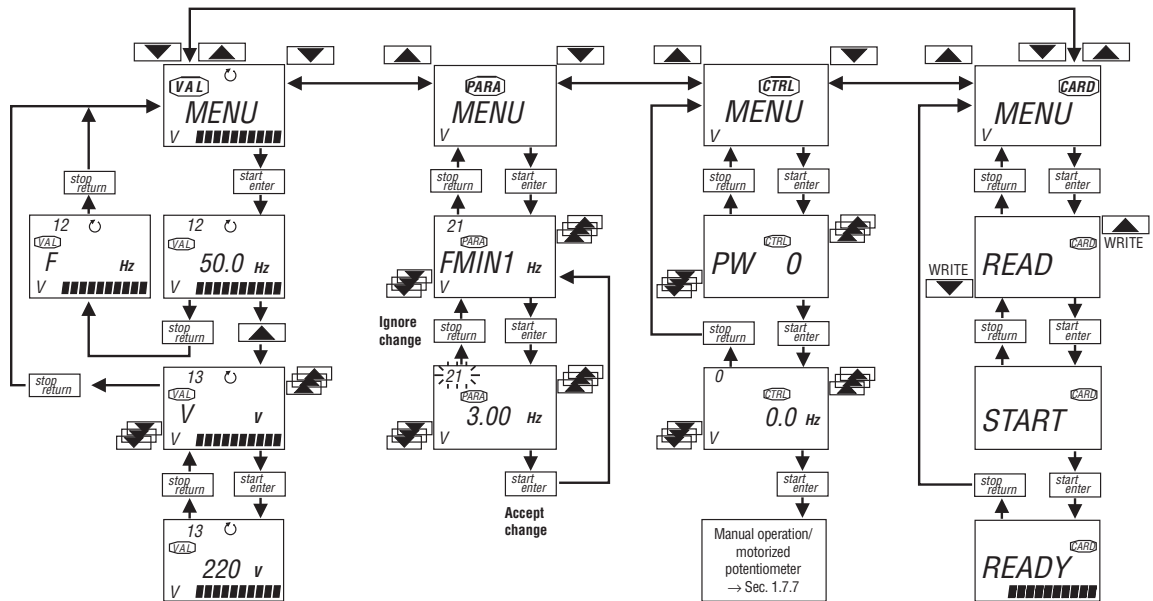

Fig. 6: Menu branches

00408BEN

Explanation of menu branches:

MENU VAL = Display values	MENU PARA = Parameter adjustment	MENU CTRL = Manual operation with FBG 01	MENU CARD = Copying with PAC 01
Display actual values e.g. output frequency.	Select parameters e.g. 21-FMIN1.	Enter password (factory setting 573).	READ = read data from PAC 01. WRITE = write data to PAC01.
Select display e.g. output voltage.	Change parameter e.g. to 3Hz.	Confirm password with [start/enter].	Confirm safety enquiry (START).
Display new actual value.	Confirm change with [start/enter] or ignore with [stop/return].	Start manual operation (→ Sec. 4.2.3).	Data are read/written.
Display parameters → Sec. 4.4.1	Parameters can only be changed when the inverter is inhibited. When the unit is enabled and started the parameters can only be read. Adjustable parameters → Sec.4.4.2	Manual operation can only be selected if the unit is inhibited.	Reading/writing data is only possible when the unit is inhibited.

4.2.3 Manual operation / motorized potentiometer

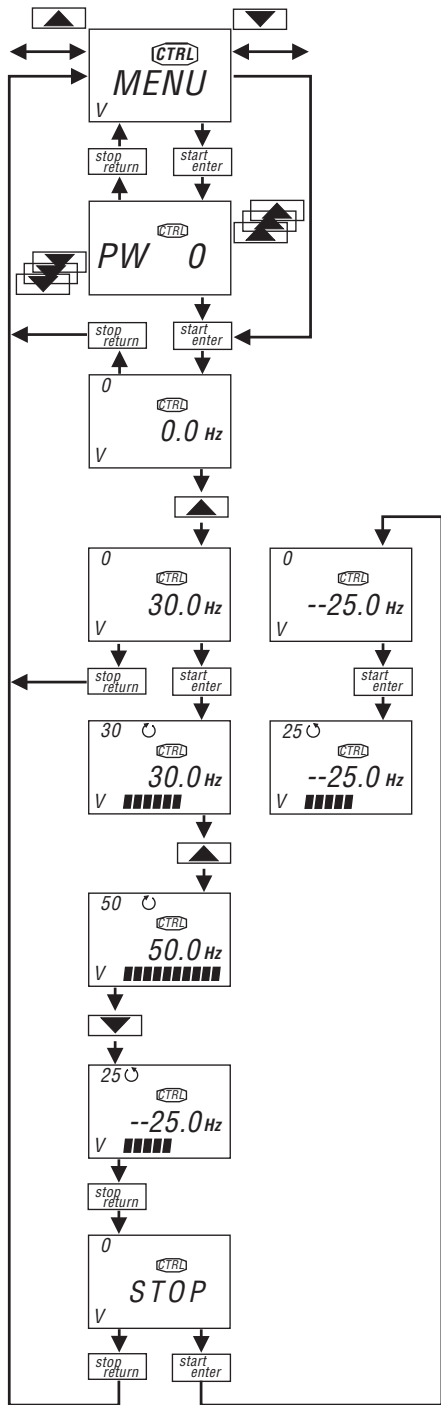

- Call up CTRL menu branch.
- Enter password (factory setting 573) and confirm.
- The frequency input for the inverter is 0Hz.
- Set the required frequency input using the arrow keys.
- Start the inverter with [start/enter], accelerate with ramp 32 RACC1.
- Change the frequency input using the arrow keys.
- To reverse input a negative frequency value. The inverter will decelerate to 0Hz using ramp 33 RDEC1, reverse and accelerate to the frequency input with ramp 32 RACC1.
- The inverter will decelerate to standstill with ramp 33 RDEC1.

Fig. 7: Manual operation / motorized potentiometer 00409AXX

4.3 Setting the signal mode for FSINA and SOUTA

The **signal mode** is set with the jumper on **jumper strip X2**:

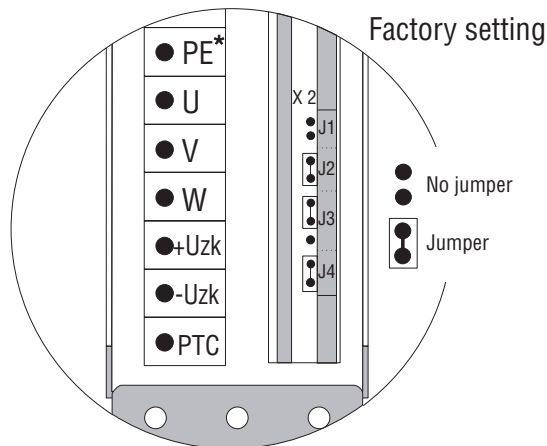

- Inhibit inverter, STR and STL = "0".
- Disconnect the inverter from the supply.
- Unscrew and remove terminal strip X1.
- Use suitable tool, e.g. pointed pliers or tweezers to change jumpers.

Fig. 8: Jumper strip X2

00404BE N

● Frequency setpoint input FSINA (X1:2)

Input signal	Jumper		PARA	Explanation
	J1	J2	04 FFSEL	
0...10 V (factory setting)	● ●	●●	4 factory setting	– setpoint potentiometer connection (4.7...10 kW) or external voltage source 0V = STOP, output inhibited / 0.1 V = FMIN / 10 V = FMAX
2...10 V	● ●	● ●		– external power supply
0...20 mA	●●	●●		
4...20 mA	●●	● ●		– "zero live" signal

● Analog/binary output SOUTA (X1:10)

Input signal	Jumper		PARA	Explanation
	J3	J4	61 SOUT	
0...10 V (factory setting)	●●●	●●	1	0...10 V \triangle 0...FMAX
			4	Apparent 200 % $I_N = 10$ V
			5	Active current 200 % $I_N = 10$ V
			6	Active power 100 % $P_D = 10$ V
No function	●●●	● ●	0	
Pulse output, PWM signal	●●●	● ●	1	Output frequency (0...FMAX) = PWM frequency (0...100 %)
Pulse output, binary signal	●●●	● ●	2	Brake chopper active
			3	6 times the output frequency
			7	only for interface mode (cannot be activated)

4.4 Complete parameter list

4.4.1 Menu branch VAL, display parameters

Level			No.	Code	Function	Range
1	2	3				
Actual Value						
		X	3	CNTL	(Not for use)X8	
		X	8	SOUT		
X	X	X	10	G	Standard output signal (10 G = 12 F x 86 KG)	0...20000
		X	11	STAT	(Not for use)	
X	X	X	12	F	Output frequency	0.00...999.00 Hz
X	X	X	13	V	Output voltage	0...230 V
X	X	X	14	IS	Apparent current	0.0...6.3 A
X	X	X	15	IW	Active current	0.0...6.3 A
X	X	X	16	PW	Active power	0...18000 W
X	X	X	17	VZK	DC link voltage	0...350 (...900)V
X	X	X	18	TIME	Operating time from reset	0.0...960.0 h
X	X	X	19	TOP	Operating hours	0...60000 h
		X	66	SIN	(Not for use)	
		X	68	FIN		
		X	83	SIOW		
		X	85	SIOF		
Inverter data						
X	X	X	91	TYPE	Inverter type	0504/0508
X	X	X	92	REV	Software version	108.10
		X	93	KOMP	(Not for use)	
X	X	X	95	ERR1	Last fault (only unit faults, not operator faults)	0-0.0...15-.15 (fault type 0...15 - time [h] between reset and fault)
		X	96	ERR2	Next to last fault	
		X	97	ERR3	2nd to last fault	
		X	98	ERR4	3rd to last fault	

4.4.2 PARA menu branch, adjustable parameters

Level			Data set		No. Code	Function	Value range (Factory setting <u>underlined</u>)	Setting after commis- sioning
1	2	3	1	2				
X	X	X			1	MODE	Operating mode	0/ <u>1</u> /2/3/4
		X			2	CSEL	(Not for use)	Do not change!
	X	X			4	FSSSEL	Frequency setpoint selector	0, <u>4</u> ...15
		X			5	FSSIO	(Not for use)	Do not change!
	X	X			9	BARG	Bar graph display	F, <u>V</u> , IS, IW, SIN, STAT
Frequencies								
X	X	X	●		20	FFS2-1	Fixed frequencies 2-1	0.00... <u>3.00</u> ...999.00
X	X	X	●		21	FMIN1	Minimum frequency	<u>0.00</u> ...999.00
X	X	X	●		22	FMAX1	Maximum frequency	4.00... <u>50.00</u> ...999.00
X	X	X			23	FF3	Fixed frequency 3	0.00... <u>15</u> ...999.00
X	X	X			24	FF4	Fixed frequency 4	0.00... <u>30</u> ...999.00
X	X	X			25	FF5	Reference frequency S2OUT	0.00... <u>3.00</u> ...999.00
	X	X			26	FF6	Control frequency (characteristic)	<u>0.00</u> ...999.00
	X	X	●		27	FF2-2	Fixed frequency 2-2	0.00... <u>5</u> ...999.00
	X	X	●		28	FMIN2	Minimum frequency	<u>0.00</u> ...999.00
	X	X	●		29	FMAX2	Maximum frequency	4.00... <u>50.00</u> ...999.00
Ramp generators								
	X	X			31	KSEL	Characteristic set selector	<u>0</u> / 1 / 2 / 3 0 always data set 1 1 data set 2 if 12 F 26 FF6 2 data set 2 if S2IND = "1" 3 data set 2 if CCW
X	X	X	●		32	RACC1	Acceleration ramp 1	0.10... <u>20.00</u> ...999.00 Hz/s
X	X	X	●		33	RDEC1	Deceleration ramp 1	0.10... <u>20.00</u> ...999.00 Hz/s
	X	X	●		34	RACC2	Acceleration ramp 2	0.10... <u>80.00</u> ...999.00 Hz/s
	X	X	●		35	RDEC2	Deceleration ramp 2	0.10... <u>80.00</u> ...999.00 Hz/s
X	X	X			36	RSTOP	Stop ramp	<u>0.00</u> ...999.00 Hz/s
Characteristic								
	X	X			38	THTDC	Switch-off delay	<u>0.00</u> ...120.00 s
	X	X			39	VHTDC	DC holding voltage	1.00... <u>4.00</u> ...25.00 %
X	X	X			41	V/FC	V/f characteristic selector	<u>1</u> /4
X	X	X	●		42	VBF	Boost 1 (starting torque)	0.00... <u>8.00</u> ...25.00 %
X	X	X	●		43	FN1	Base (rated) frequency 1	26.00... <u>50.00</u> ...960.00 Hz
X	X	X	●		44	VN1	Rated voltage 1	110... <u>220</u> ...240 V
	X	X	●		45	VB2	Boost 2 starting torque)	0.00... <u>8.00</u> ...25.00 %
	X	X	●		46	FN2	Base (rated) frequency 2	26.00... <u>50.00</u> ...960.00 Hz
	X	X	●		47	VN2	Rated voltage 2	110... <u>220</u> ...240 V

Level			Data set		No	Code	Function	Value range (Factory setting underlined)	Setting after commis- sioning
1	2	3	1	2					
	X	X			48	IxR	I x R compensation	<u>0</u> ...1	
	X	X			49	SC	Slip compensation	<u>0</u> ...1	
	X	X			50	IN	Motor rated current	MC 0504: <u>0.00</u> ...2.85 A MC 0504: <u>0.00</u> ...4.80 A	
	X	X			51	COS	Power factor x 100	0.00...100.00	
	X	X			52	NN	Motor rated speed	0...60,000 rpm	
	X	X			53	KIXR	K factor IxR compensation	0... <u>1</u> .255	
	X	X			54	KSC	K factor IxR slip compensation	0.00...30.00	
	X	X			55	ISEL	Current controller selector	0...2	
	X	X			56	ILIM	Current limit	MC0504: 0.50. <u>2.85</u> ...3.80 A MC0508: 0.50. <u>2.85</u> ...5.75 A	
	X	X			57	FILIM	Min. low. frequency	0.00... <u>15.00</u> ...999.00 Hz	
	X	X			58	RILIM	Deceleration ramp I control	0.10... <u>50.00</u> ...999.00 Hz/s	
	X	X			59	TRIP	Ixt monitoring motor	MC0504: 0.50...1.90...2.00 A MC0508: 0.90... <u>3.20</u> A	
Control functions									
	X	X			61	SOUTA	Analog output X1:10	0... <u>1</u> ...7 (→ Sec. 3.4/4.3)	
	X	X			62	S1OUT	Digital output 1 X1:8	0... <u>1</u> ...10 (→ Sec. 3.4)	
	X	X			63	S2OUT	Digital output 2 X1:9	1... <u>7</u> ...10 (→ Sec. 3.4)	
	X	X			64	SINA	Potentiometer 1 (internal)	0...2	
		X			65	SINT	(Not for use)		Do not change!
	X	X			67	FST	Filter time constant	0... <u>2</u> ...4	
	X	X			69	KOUTA	SOUTA scaling	0... <u>100</u> ...200%	
Program									
	X	X			71	PROG	Factory programming	<u>0</u> ...9999 0 = inactive / 1 = active / 2 = special prog.	
	X	X			72	STRT	Start option	0...7 0=none / 1=autostart / 2=flying start / 3=1+2 / CCW inhibited / 5=1+4 / 6=2+4 / 7=1+2+4	
	X	X			74	PWM	PWM frequency	<u>0</u> ...2 (<u>7.8</u> /15.6/3.9kHz)	Do not change!
		X			75	OPT1	(Not for use)		
		X			76	OPT2			
		X			77	OPT3			
		X			81	SIOC			
		X			82	SIOA			
		X			84	SIOT			
	X	X			86	KG	Scaling factor 10-G	0...1000	
	X	X			87	DISP	Actual value display	<u>E</u> , all values VAL	
	X	X			88	PSW1	Password 1 <PARA>	0...999	
	X	X			89	PSW2	Password 2 <CTRL>	0.. <u>573</u> ...999	
		X			94	MAXF	Absolute maximum frequency	0...999 Hz	

5.1 Operating displays

The LED operating displays indicate the following:

H1 (red)	H2 (green)	Indication
OFF	OFF	Mains supply OFF
ON	OFF	Mains supply ON, inverter is ready for operation
OFF	ON	Inverter started
ON	ON	Inverter started and overload protection active
BLINKING	OFF	Fault indication by inverter (for fault information details → Sec. 5.3)

5.2 Operating conditions / Overload condition

Operating conditions:

Command	Operation	Drive response
STR or STL = "1"	Start	Inverter is ready for operation, drive is not running.
STR or STL = "1" and FSINA ≥ 0.1 V (or fixed frequency selection)	Start +setpoint	Drive accelerates with ramp 32 RACC1 or 32 RACC2 in selected direction of rotation.
Transition "0" and "1" on STR and STL	Reversal	Drive decelerates with ramp 33 RDEC1 or 35 RDEC2, reverses and accelerates with ramp 32 RACC1 or 34 RACC2.
STR and STL = "1" Important: not fail-safe!	Deceleration with deceleration ramp	Drive decelerates with ramp 33 RDEC1 or 35 RDEC2.
STR and STL = "0"	Output voltage = 0	36 STOP = 0 → motor uncontrolled, coasts to rest.
	Stop with stop ramp	36 STOP > 0 → motor decelerates with stop ramp 36 STOP.
Power down (K11)	EMERGENCY STOP	After power down wait for minimum 30s before you power the inverter up again.

Overload condition:

An overcurrent of 150% I_N for max. 60 seconds is permissible. If the thermal loading is too high the Ixt monitoring will shut down the unit and generate a fault message (→ Sec. 5.3).

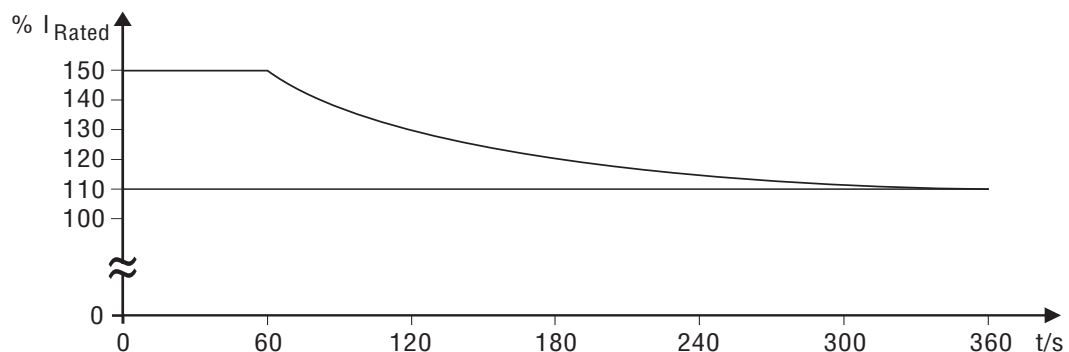

Fig. 9: Overload characteristic

0041AEN

The overload rating is based on rated data, i.e. PWM frequency = 7.8 kHz (factory setting → 4.4.2 PARA 74 PWM) and ambient temperature = 40 °C.

5.3 Fault information

In the event of a fault the LED H1 will keep flashing (red).

LED H1 (red) flashing	Cause	Remedy / Comments
I once	Processor fault	Reset, power down and power up again
II twice	Power down, flashing up to $V_{DC \text{ link}} < 65 \text{ V}$	Automatic reset
	Undervoltage, flashing up to $V_{\text{mains}} < 155 \text{ V}$	Check power supply and power cable
III 3 times	Trip on overcurrent $I > 300\% I_N$	Check drive
	Short circuit	Check motor cable
IIII 4 times	Overvoltage $V_{DC \text{ link}} > 408 \text{ V}$	Check supply
	Motor regenerating	Check drive, BRC 03 may be necessary
IIIII 5 times	Ixt trip motor	Motor overloaded, check drive (setting parameter 59 ITRIP)
IIIIII 6 times	Ixt trip inverter	Inverter overloaded, check drive
IIIIIII 7 times	Motor overtemperature	Motor overloaded, check drive or check PTC thermistor connection or jumper X5:-/PTC
IIIIIIII 8 times	Inverter overtemperature	Inverter overloaded, check installation and ambient conditions
IIIIIIIII 9 times	EPROM fault	Reset, power down and power up again

Reset:

To clear a fault message power the unit down and then up again. Wait for minimum 30 seconds before you power the inverter up again.

Fault memory:

The last four faults are saved and can be read out as display parameters 95 ERR1 in the VAL menu branch, using the FBG 01 keypad. Details saved are the type of error and the operating time up to fault occurrence.

If the FBG 01 control unit is plugged in at the time the fault occurs, display parameters VAL 12 F, 13 V, 14 IS, 15 IW and 17 VZK are frozen at the time the fault occurs and can be read out until the unit is reset.

The FBG 01 keypad indicates the faults the same as the basic unit, and in addition signals the following faults:

Code	Meaning	In fault memory VAL 95 ERR1
Operating errors		
ATT1	Parameter adjustment not allowed while motor is running	
ATT2	Manual operation via FBG 01 keypad not allowed if motor is already running	
ATT3	Access to ParaCard PAC 01 not allowed while motor is running	
ATT4	System in fault condition; manual operation via FBG 01 not allowed	
ATT5	Motor data must be complete for selected function (e.g. for 48 lxR compensation)	
ERROR	Invalid password	
Errors ParaCard PAC 01		
ERR91	PAC 01 write-protected	
ERR92	Plausibility check error	
ERR93	Unable to read PAC 01, wrong inverter type	
ERR94	Unable to read PAC 01, parameter data not compatible	
ERR96	Connection to PAC 01 interrupted	
ERR97	PAC 01 invalid (CS test)	
Inverter faults		
E-CPU	Fault in processor pcb (AUTOSTART in 72 START causes reset)	1
E-OFF	Undervoltage (no entry in fault memory)	
E-OC	Overcurrent/short-circuit after power up, earth circuit	3
E-OV	Overvoltage	4
E-OLM	lxt motor	5
E-OLI	lxt inverter	6
E-OTM	Overtemperature motor (only with PTC thermistor connection)	7
E-OTI	Inverter overtemperature	8
E-EEP	EEPROM fault	9
E-PWR	Power section not recognized	10

5.4 SEW Electronics Service

If a fault cannot be reset, then please contact the **SEW Electronics Service** (→ "After-Sales and Spare Parts Service").

If you return equipment for repair, please:

- describe the nature and extent of the fault
- explain when and under what background conditions the fault occurred
- state the suspected cause
- state any abnormal circumstances, etc. that may have preceded the fault.

6.1 Basic units

MOVITRAC® type		0504-231-1	0508-231-1
Inverter part number 1Q		825 877 5	825 878 3
Rated output power (at $V_{\text{mains}} = 1 \times 230 \text{ V}_{\text{AC}}$)	P_{N}	0.75 kVA	1.27 kVA
Continuous output power (110% P_{N}) (at $V_{\text{mains}} = 1 \times 230 \text{ V}_{\text{AC}}$)	P_{cont}	0.84 kVA	1.4 kVA
Rated supply voltage Permissible range	V_{mains}	1 x 220 V_{AC} / 230 V_{AC} / 240 V_{AC} $V_{\text{mains}} = 200 \text{ V}_{\text{AC}} - 10\% \dots 240 \text{ V}_{\text{AC}} + 6\%$	
Mains frequency	f_{mains}	50 Hz...60 Hz $\pm 10\%$	
Mains rated current	I_{mains}	3.8 AAC	6.3 AAC
Output voltage	V_{outp}	Setting value PARA 44 VN1 or 47 VN2 however max. V_{mains}	
PWM frequency	f_{PWM}	Setting value PARA 74 PWM (7.8 kHz / 15.6 kHz / 3.9 kHz)	
Output frequency	f_{outp}	Permissible setting range: 0...400 Hz $f_{\text{min}} = 0...400 \text{ Hz}$ $f_{\text{max}} = 4.0...400 \text{ Hz}$ Resolution $\Delta f_{\text{outp}} = 0.1\% f_{\text{max}}$, maximum 0.05 Hz	
Output rated current	I_{N}	1.9 AAC	3.2 AAC
Recommended motor power	P_{mot}	0.375 kW	0.75 kW
Continuous output current $I_{\text{cont}}=110\% I_{\text{N}}$	I_{cont}	2.1 AAC	3.5 AAC
Overload		motoring: 150% I_{N} or 138% I_{cont} for $t = 60 \text{ s}$	
Braking resistor for 4Q operation		BRC 03 with integrated braking resistor	
Interference emission with EMC-compliant installation (mains input filter + screened motor cable)		to class B limit to EN 55011 + EN 55014, complies with EN 50081 - Parts 1 and 2	
Immunity		complies with EN 50082 - Parts 1 and 2	
Ambient temperature	ϑ_{amb}	0...+40°C (P_{N} derating: 3.0% I_{N} per K up to max. 60°C)	
Storage temperature	$\vartheta_{\text{storage}}$	- 25°...+70°C	
Enclosure		IP 20 (EN 60529)	
Duty type		DB continuous (EN 60146-1)	
Power losses at P_{N}	$P_{\text{loss max}}$	25 W	35 W
Type of cooling		KS = natural cooling (DIN 41 751)	
Altitude of installation		$h \leq 1000 \text{ m}$ (P_{N} derating: 5% per 1000 m from 1000 m to max. 2000 m)	
Weight		1 kg	
Main dimensions basic unit WxHxD		6 x 183 x 137 mm	
Mounting dimensions		40 x 170 mm	
Hole size		4.8 mm	

Power ratings are based on a **factory-set** PWM frequency of 7.8 kHz.

To provide sufficient cooling leave the **following** minimum **clearances**:

- **With FKS 01 heat sink:**
above and below each unit 50 mm and 30 mm on each side
- **Without heat sink mounted to switch cabinet rear panel:**
above and below each unit 200 mm, 200 mm on each side, i.e. cooling area min. 0.25 m²

MOVITRAC® series 0500		General electronic data
Speed setpoints	X1:1	Reference voltage for setpoint potentiometer: $+10 V_{DC} \pm 2\%$ Current rating $I_{max} = 15 \text{ mA}$, short-circuit proof Reference potential X1:7 or X1:11
External setpoint inputs (selectable via jumpers J1 / J2)	X1:2	$n = 0...+10 \text{ V} / 2...10 \text{ V}$ $R_i = 100 \text{ k}\Omega$ resolution: 10 bit Linearity < 2% in the range of $0...10 \text{ V}$ sample time: 8.2 ms $n = 0...20 \text{ mA} / 4...20 \text{ mA}$ $R_i = 500 \Omega$
Frequency ramp generator time range		Acceleration ramp and deceleration ramp separately adjustable Range: $0.10...999.00 \text{ Hz/s}$ STOP ramp adjustable, range: $0.00...999.00 \text{ Hz/s}$
Binary inputs		Input voltage = $0...30 \text{ V}$ $R_i = 4.7 \text{ k}\Omega$ sample time $\leq 8.2 \text{ ms}$ Reference potential X1:7 or X1:11 electrically isolated by optocouplers
Input mode		$(+ 8...30) \text{ V} = "1" = \text{contact closed}$ $(0...+ 2) \text{ V} = "0" = \text{contact open}$
Control functions	X1:3 <STR> X1:4 <STL> X1:5 <S1IND> X1:6 <S2IND>	Start CW Start CCW Fixed frequency 1/ 2/ 3 (3 fixed frequencies) programmable
Binary outputs		open collector low active electrically isolated by optocouplers $V_{max} = 30 \text{ V}$ $R_i = 100 \Omega$ Current rating $I_{max} = 50 \text{ mA}$ Important: not short-circuit proof, not external-voltage-proof Reference potential: ground X1:7 or X1:11
	X1:8 OUT X1:9 OUT	Programmable: collective fault / output voltage / CW / CCW / motor standstill / setpoint reached / frequency limit FF5 exceeded / current limit / brake chopper active / unit shutdown on faults
Output	X1:10 analog	Analog output signal: $(0...+10 \text{ V}) \times (0...200\%)$ tolerance $\pm 2\%$ Current rating $I_{max} = 2 \text{ mA}$ $R_i = 100 \Omega$ resolution: 10 bit Important: not short-circuit-proof, not external-voltage-proof programmable: output frequency / apparent current / active current / active power
(selectable via jumpers J3 / J4)	digital	PWM or binary signal Open collector $V_{max} = 15 \text{ V}$ Current rating $I_{max} = 15 \text{ mA}$ $R_i = 100 \text{ W}$ resolution: < 0.3 Hz Important: not short-circuit-proof, not external-voltage-proof Programmable: output frequency / brake chopper active
Reference terminals	1:7, X1:11	Reference potential for X1:1, X1:2-X1:6 and X1:8-X1:10
PTC input	X5: - / PTC	PTC = PTC thermistor = TF thermistor in motor non-isolated (referred to supply potential) $R_{PTC \text{ thermistor}}$ at rated response temperature > 3 k Ω (DIN 44081) Recommendation: TF.. PTC thermistors If no PTC thermistor is used, terminals X5/- and X5/PTC must be jumpered.



6.2 BRC 03 brake chopper with integral braking resistor

Brake chopper type		BRC 03
Part number		826 398 1
Regenerative power rating	100% cdf* 50% cdf 25% cdf 12% cdf 6% cdf	90 W 140 W 210 W 310 W 450 W
Resistance value		97Ω
Peak regen. rating	P _{regen}	1.5 kW (after 6s reduction to 700)
Max. current		4.0 A _{AC}
Design		Heating cartridge
Electrical connection		Ceramic terminals for 1.5 mm ²
Enclosure		IP 10 (when mounted)
Operating ambient temperature		0...+40°C
Type of cooling		KS - natural cooling (heat dissipation via mounting surface)
Weight		0.5 kg
Dimensions W x H x D		65 x 183 x 137mm
Mounting dimensions		40 x 170 mm, hole size 4.8 mm
For use with MOVITRAC [®] type		0504-231-1 / 0508-231-1

* cdf = cyclic duration factor

6.3 NF..-231 input filter

Input filter type	NF 005-231	NF 008-231
Part number	825 881 3	825 882 1
Rated current	I _N 5 A _{AC}	8 A _{AC}
Rated voltage	V _N 1 x 230 V (max. = 250 V _{AC})	
Mains frequency	f _{mains} 50/60 Hz	
AC leakage current at V _N (f _{mains} = 60 Hz) determined under worst-case conditions	2 mA	1.5 mA
Ambient temperature	ϑ _{amb} -25...+45°C	
Enclosure	IP 00 (DIN 40 050)	
Connection	flat connector 6.3 x 0.8 mm	
Dimensions W x H x D	52 x 90.6 x 40 mm	50.8 x 159 x 44.5 mm
Mounting dimension (one mounting hole ea. at the top and bottom on the centre line)	75 mm	142.9 mm
Hole size	5.3 mm	4.7 mm
For use with MOVITRAC [®] type	0504-231-1	0508-231-1